

30 W Digital TV Amplifier with Integrated ADC

Digital Amplifier Features

- ◆ Fully Integrated Power MOSFETs
- ◆ No Heatsink Required
 - Programmable Power Foldback on Thermal Warning
 - High Efficiency (85%)
- ◆ > 100 dB Dynamic Range
- ◆ < 0.1% THD+N @ 1 W
- ◆ Configurable Outputs (10% THD+N)
 - 1 x 30 W into 4 Ω, Parallel Full-Bridge
 - 2 x 15 W into 8 Ω, Full-Bridge
 - 2 x 7 W into 4 Ω, Half-Bridge + 1 x 15 W into 8 Ω, Full-Bridge
- ◆ Built-In Protection with Error Reporting
 - Overcurrent/Undervoltage/Thermal Overload Shutdown
 - Thermal Warning Reporting
- ◆ PWM Popguard® for Half-Bridge Mode
- ◆ Click Free Start-Up
- ◆ Programmable Channel Delay for System Noise & Radiated Emissions Management

ADC Features

- ◆ Stereo, 24-bit, 48 kHz Conversion
- ◆ Multi-bit Architecture
- ◆ 95 dB Dynamic Range (A-wtd)
- ◆ -88 dB THD+N
- ◆ 2 Vrms Input Supports SCART

System Features

- ◆ Asynchronous 2-Channel Digital Serial Port
- ◆ 32 kHz to 96 kHz Input Sample Rates
- ◆ Operation with On-Chip Oscillator Driver or Applied SYS_CLK at 18.432, 24.576 or 27.000 MHz
- ◆ Integrated Sample Rate Converter (SRC)
 - Eliminates Clock-Jitter Effects
 - Input Sample Rate Independent Operation
 - Simplifies System Integration
- ◆ Spread Spectrum PWM Modulation
 - Reduces EMI Radiated Energy
- ◆ Low Quiescent Current

(Features continued on [page 2](#))

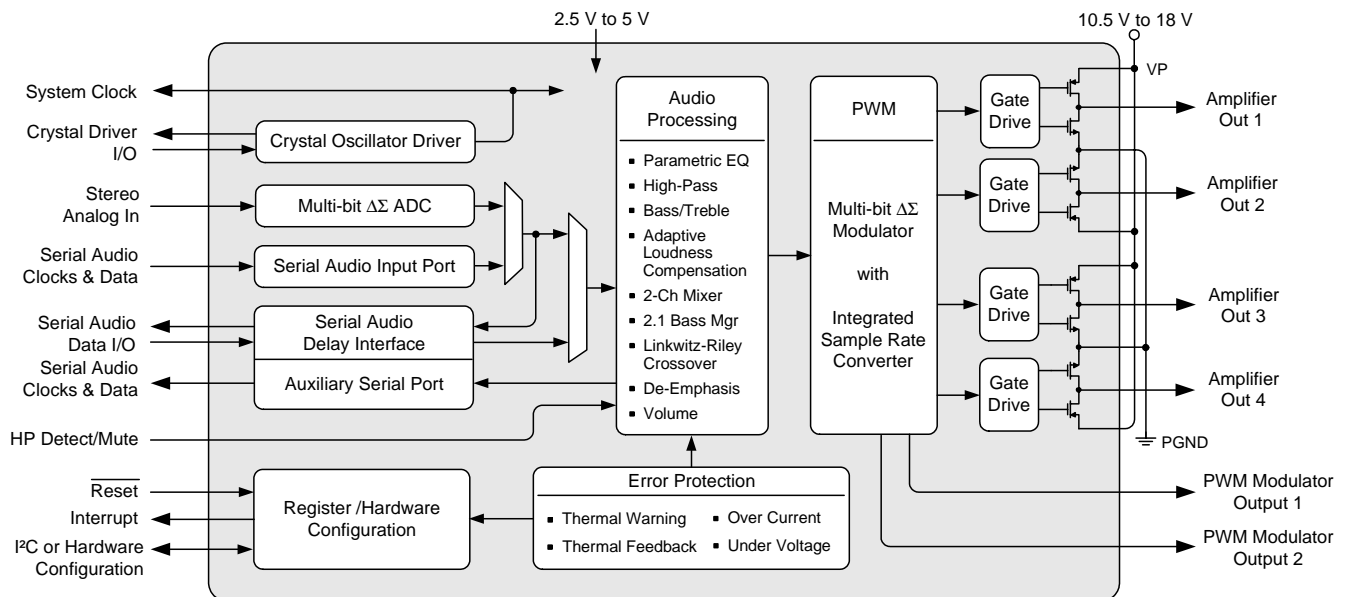

Software Mode System Features

- ◆ Digital Audio Processing
 - 3 Programmable Parametric EQ Filters for Channels 1 and 2
 - 2 Programmable Parametric EQ Filters for Channel 3
 - Selectable High-Pass Filter
 - Bass/Treble Tone Control
 - Adaptive Loudness Compensation
 - 2-Channel Mixer
 - 2.1 Bass Management
 - 24 dB/octave Linkwitz-Riley Crossover Filters
 - De-emphasis for 32 kHz, 44.1 kHz, 48 kHz
- ◆ Selectable Serial Audio Interface Formats
 - Left-Justified up to 24-bit
 - I²S up to 24-bit
 - Right-Justified 16-, 18-, 20-, 24-bits
- ◆ Digital Serial Connection to Additional CS4525 or DACs for Subwoofer
- ◆ Digital Interface to External Lip-Sync Delay
- ◆ PWM Switch Rate Shifting Eliminates AM Frequency Interference
- ◆ Digital Volume Control with Soft ramp
 - +24 to -103 dB in 0.5 dB steps
- ◆ Programmable Peak Detect and Limiter
- ◆ Flexible Power Output Configurations
- ◆ Thermal Foldback for Interruption-Free Power-Stage Protection
 - Supports Internal and External Power Stages
- ◆ Operation from On-Chip Oscillator Driver or Applied Systems Clock
- ◆ Supports I²C[®] Host Control Interface

Hardware Mode System Features

- ◆ 2-Channel Stereo Full-Bridge Power Outputs
- ◆ Analog and Digital Inputs
- ◆ I²S and Left-Justified Serial Input Formats
- ◆ Thermal Foldback for Interruption-Free Protection of Internal Power Stage
- ◆ Operation from Applied Systems Clock
- ◆ External Mute Input

Common Applications

- ◆ Integrated Digital TV's
- ◆ Flat Panel TV Monitors
- ◆ Computer/TV Monitors
- ◆ Mini/Micro Shelf Systems
- ◆ Digital Powered Speakers
- ◆ Portable Docking Stations
- ◆ Computer Desktop Audio

General Description

The CS4525 is a stereo analog or digital input PWM high efficiency Class D amplifier audio system with an integrated stereo analog-to-digital (A/D) converter. The stereo power amplifiers can deliver up to 15 W per channel into 8 Ω speakers from a small space saving 48-pin QFN package. The PWM amplifier can achieve greater than 85% efficiency and the package is thermally enhanced for optimal heat dissipation which eliminates the need for a heatsink.

The power stage outputs can be configured as two full-bridge channels for 2 x 15 W operation, two half-bridge channels and one full-bridge channel for 2 x 7 W + 1 x 15 W operation, or one parallel full-bridge channel for 1 x 30 W operation. The CS4525 integrates on-chip over-current, under-voltage, over-temperature protection and error reporting as well as a thermal warning indicator and programmable foldback of the output power to allow cooling.

The main digital serial port on the CS4525 can support asynchronous operation with the integrated on-chip sample rate converter (SRC) which eases system integration. The SRC allows for a fixed PWM switching frequency regardless of incoming sample rate as well as optimal clocking for the A/D modulators.

An on-chip oscillator driver eliminates the need for an external crystal oscillator circuit, reducing overall design cost and conserving circuit board space. The CS4525 automatically uses the on-chip oscillator driver in the absence of an applied master clock.

The CS4525 is available in a 48-pin QFN package in Commercial grade (-10° to +70° C). The CRD4525 Customer Reference Design is also available.

Please refer to [“Ordering Information” on page 90](#) for complete ordering information.

TABLE OF CONTENTS

1. PIN DESCRIPTIONS - SOFTWARE MODE	8
2. PIN DESCRIPTIONS - HARDWARE MODE	10
2.1 Digital I/O Pin Characteristics	12
3. TYPICAL CONNECTION DIAGRAMS	13
4. TYPICAL SYSTEM CONFIGURATION DIAGRAMS	15
5. CHARACTERISTIC AND SPECIFICATION TABLES	18
SPECIFIED OPERATING CONDITIONS	18
ABSOLUTE MAXIMUM RATINGS	18
ANALOG INPUT CHARACTERISTICS	19
ADC DIGITAL FILTER CHARACTERISTICS	19
PWM POWER OUTPUT CHARACTERISTICS	20
SERIAL AUDIO INPUT PORT SWITCHING SPECIFICATIONS	21
AUX SERIAL AUDIO I/O PORT SWITCHING SPECIFICATIONS	22
XTI SWITCHING SPECIFICATIONS	23
SYS_CLK SWITCHING SPECIFICATIONS	23
PWM_SIGX SWITCHING SPECIFICATIONS	23
I ² C CONTROL PORT SWITCHING SPECIFICATIONS	24
DC ELECTRICAL CHARACTERISTICS	25
DIGITAL INTERFACE SPECIFICATIONS	25
6. APPLICATIONS	26
6.1 Software Mode	26
6.1.1 System Clocking	26
6.1.1.1 SYS_CLK Input Clock Mode	26
6.1.1.2 Crystal Oscillator Mode	27
6.1.2 Power-Up and Power-Down	28
6.1.2.1 Recommended Power-Up Sequence	28
6.1.2.2 Recommended Power-Down Sequence	28
6.1.3 Input Source Selection	28
6.1.4 Digital Sound Processing	29
6.1.4.1 Pre-Scaler	29
6.1.4.2 Digital Signal Processing High-Pass Filter	30
6.1.4.3 Channel Mixer	30
6.1.4.4 De-Emphasis	31
6.1.4.5 Tone Control	31
6.1.4.6 Parametric EQ	33
6.1.4.7 Adaptive Loudness Compensation	34
6.1.4.8 Bass Management	35
6.1.4.9 Volume and Muting Control	36
6.1.4.10 Peak Signal Limiter	37
6.1.4.11 Thermal Foldback	39
6.1.4.12 2-Way Crossover & Sensitivity Control	41
6.1.5 Auxiliary Serial Output	42
6.1.6 Serial Audio Delay & Warning Input Port	42
6.1.6.1 Serial Audio Delay Interface	42
6.1.6.2 External Warning Input Port	43
6.1.7 PWM Output Configuration	43
6.1.7.1 PWM Power Output Configurations	43
6.1.7.2 PWM_SIG Logic-Level Output Configurations	44
6.1.7.3 PWM PopGuard Transient Control	45
6.1.7.4 PWM Channel Delay	46
6.1.7.5 PWM AM Frequency Shift	47
6.1.8 Headphone Detection & Hardware Mute Input	47

6.1.9	Interrupt Reporting	48
6.1.10	Automatic Power Stage Shut-Down	48
6.2	Hardware Mode	49
6.2.1	System Clocking	49
6.2.2	Power-Up and Power-Down	49
6.2.2.1	Recommended Power-Up Sequence	49
6.2.2.2	Recommended Power-Down Sequence	49
6.2.3	Input Source Selection	50
6.2.4	PWM Channel Delay	50
6.2.5	Digital Signal Flow	51
6.2.5.1	High-Pass Filter	51
6.2.5.2	Mute Control	51
6.2.5.3	Warning and Error Reporting	51
6.2.6	Thermal Foldback	52
6.2.7	Automatic Power Stage Shut-Down	53
6.3	PWM Modulators and Sample Rate Converters	53
6.4	Output Filters	54
6.4.1	Half-Bridge Output Filter	54
6.4.2	Full-Bridge Output Filter (Stereo or Parallel)	55
6.5	Analog Inputs	56
6.6	Serial Audio Interfaces	57
6.6.1	I ² S Data Format	57
6.6.2	Left-Justified Data Format	57
6.6.3	Right-Justified Data Format	58
6.7	I ² C Control Port Description and Timing	59
7.	PCB LAYOUT CONSIDERATIONS	60
7.1	Power Supply, Grounding	60
7.1.1	Integrated VD Regulator	60
7.2	QFN Thermal Pad	60
8.	REGISTER QUICK REFERENCE	61
9.	REGISTER DESCRIPTIONS	64
9.1	Clock Configuration (Address 01h)	64
9.1.1	SYS_CLK Output Enable (EnSysClk)	64
9.1.2	SYS_CLK Output Divider (DivSysClk)	64
9.1.3	Clock Frequency (ClkFreq[1:0])	64
9.1.4	HP_Detect/Mute Pin Active Logic Level (HP/MutePol)	65
9.1.5	HP_Detect/Mute Pin Mode (HP/Mute)	65
9.1.6	Modulator Phase Shifting (PhaseShift)	65
9.1.7	AM Frequency Shifting (FreqShift)	65
9.2	Input Configuration (Address 02h)	66
9.2.1	Input Source Selection (ADC/SP)	66
9.2.2	ADC High-Pass Filter Enable (EnAnHPF)	66
9.2.3	Serial Port Sample Rate (SPRate[1:0]) - Read Only	66
9.2.4	Input Serial Port Digital Interface Format (DIF [2:0])	66
9.3	AUX Port Configuration (Address 03h)	67
9.3.1	Enable Aux Serial Port (EnAuxPort)	67
9.3.2	Delay & Warning Port Configuration (DlyPortCfg[1:0])	67
9.3.3	Aux/Delay Serial Port Digital Interface Format (AuxI ² S/LJ)	67
9.3.4	Aux Serial Port Right Channel Data Select (RChDSel[1:0])	67
9.3.5	Aux Serial Port Left Channel Data Select (LChDSel[1:0])	68
9.4	Output Configuration Register (Address 04h)	68
9.4.1	Output Configuration (OutputCfg[1:0])	68
9.4.2	PWM Signals Output Data Select (PWMDSel[1:0])	68
9.4.3	Channel Delay Settings (OutputDly[3:0])	68

9.5	Foldback and Ramp Configuration (Address 05h)	69
9.5.1	Enable Thermal Foldback (EnTherm)	69
9.5.2	Lock Foldback Adjust (LockAdj)	69
9.5.3	Foldback Attack Delay (AttackDly[1:0])	69
9.5.4	Enable Foldback Floor (EnFloor)	70
9.5.5	Ramp Speed (RmpSpd[1:0])	70
9.6	Mixer / Pre-Scale Configuration (Address 06h)	70
9.6.1	Pre-Scale Attenuation (PreScale[2:0])	70
9.6.2	Right Channel Mixer (RChMix[1:0])	70
9.6.3	Left Channel Mixer (LChMix[1:0])	71
9.7	Tone Configuration (Address 07h)	71
9.7.1	De-Emphasis Control (DeEmph)	71
9.7.2	Adaptive Loudness Compensation Control (Loudness)	71
9.7.3	Digital Signal Processing High-Pass Filter (EnDigHPF)	71
9.7.4	Treble Corner Frequency (TrebFc[1:0])	72
9.7.5	Bass Corner Frequency (BassFc[1:0])	72
9.7.6	Tone Control Enable (EnToneCtrl)	72
9.8	Tone Control (Address 08h)	72
9.8.1	Treble Gain Level (Treb[3:0])	72
9.8.2	Bass Gain Level (Bass[3:0])	73
9.9	2.1 Bass Manager/Parametric EQ Control (Address 09h)	73
9.9.1	Freeze Controls (Freeze)	73
9.9.2	Bass Cross-Over Frequency (BassMgr[2:0])	73
9.9.3	Enable LFE Parametric EQ (EnLFEPEq)	74
9.9.4	Enable Channel B Parametric EQ (EnChBPEq)	74
9.9.5	Enable Channel A Parametric EQ (EnChAPEq)	74
9.10	Volume and 2-Way Cross-Over Configuration (Address 55h)	75
9.10.1	Soft Ramp and Zero Cross Control (SZCMode[1:0])	75
9.10.2	Enable 50% Duty Cycle for Mute Condition (Mute50/50)	75
9.10.3	Auto-Mute (AutoMute)	75
9.10.4	Enable 2-Way Crossover (En2Way)	76
9.10.5	2-Way Cross-Over Frequency (2WayFreq[2:0])	76
9.11	Channel 1-2: 2-Way Sensitivity Control (Address 56h)	76
9.11.1	Channel 1 and Channel 2 Low-Pass Sensitivity Adjust (LowPass[3:0])	76
9.11.2	Channel 1 and Channel 2 High-Pass Sensitivity Adjust (HighPass[3:0])	77
9.12	Master Volume Control (Address 57h)	77
9.12.1	Master Volume Control (MVol[7:0])	77
9.13	Channel 1, 2, & 3 Volume Control (Address 58h, 59h, & 5Ah)	78
9.13.1	Channel X Volume Control (ChXVol[7:0])	78
9.14	Mute/Invert Control (Address 5Bh)	78
9.14.1	ADC Invert Signal Polarity (InvADC)	78
9.14.2	Invert Signal Polarity (InvChX)	78
9.14.3	ADC Channel Mute (MuteADC)	78
9.14.4	Independent Channel Mute (MuteChX)	79
9.15	Limiter Configuration 1 (Address 5Ch)	79
9.15.1	Maximum Threshold (Max[2:0])	79
9.15.2	Minimum Threshold (Min[2:0])	79
9.15.3	Peak Signal Limit All Channels (LimitAll)	79
9.15.4	Peak Detect and Limiter Enable (EnLimiter)	80
9.16	Limiter Configuration 2 (Address 5Dh)	80
9.16.1	Limiter Release Rate (RRate[5:0])	80
9.17	Limiter Configuration 3 (Address 5Eh)	80
9.17.1	Limiter Attack Rate (ARate[5:0])	80
9.18	Power Control (Address 5Fh)	81

9.18.1 Select VD Level (SelectVD)	81
9.18.2 Power Down ADC (PDnADC)	81
9.18.3 Power Down PWM Power Output X (PDnOutX)	81
9.18.4 Power Down (PDnAll)	81
9.19 Interrupt Register (Address 60h)	82
9.19.1 SRC Lock State Transition Interrupt Bit (SRCLock)	82
9.19.2 ADC Overflow Interrupt Bit (ADCOvfl)	82
9.19.3 Channel Overflow Interrupt Bit (ChOvfl)	82
9.19.4 Amplifier Error Interrupt Bit (AmpErr)	83
9.19.5 Mask Bit for SRC State (SRCLockM)	83
9.19.6 Mask Bit for ADC Overflow (ADCOvflM)	83
9.19.7 Mask Bit for Channel X Overflow (ChOvflM)	84
9.19.8 Mask Bit for Amplifier Error (AmpErrM)	84
9.20 Interrupt Status Register (Address 61h) - Read Only	84
9.20.1 SRC State Transition (SRCLockSt)	84
9.20.2 ADC Overflow (ADCOvfl)	85
9.20.3 Channel X Overflow (ChXOvfl)	85
9.20.4 Ramp-Up Cycle Complete (RampDone)	85
9.21 Amplifier Error Status (Address 62h) - Read Only	85
9.21.1 Over-Current Detected On Channel X (OverCurrX)	85
9.21.2 External Amplifier State (ExtAmpSt)	86
9.21.3 Under Voltage Detected (UnderV)	86
9.21.4 Thermal Error Detected (ThermErr)	86
9.21.5 Thermal Warning Detected (ThermWarn)	86
9.22 Chip I.D. and Revision Register (Address 63h) - Read Only	87
9.22.1 Device Identification (DeviceID[4:0])	87
9.22.2 Device Revision (RevID[2:0])	87
10. PARAMETER DEFINITIONS	88
11. REFERENCES	88
12. PACKAGE DIMENSIONS	89
13. THERMAL CHARACTERISTICS	90
13.1 Thermal Flag	90
14. ORDERING INFORMATION	90
15. REVISION HISTORY	91

LIST OF FIGURES

Figure 1. Typical Connection Diagram - Software Mode	13
Figure 2. Typical Connection Diagram - Hardware Mode	14
Figure 3. Typical System Configuration 1	15
Figure 4. Typical System Configuration 2	15
Figure 5. Typical System Configuration 3	16
Figure 6. Typical System Configuration 4	17
Figure 7. Serial Audio Input Port Timing	21
Figure 8. AUX Serial Port Interface Master Mode Timing	22
Figure 9. SYS_CLK Timing from Reset	23
Figure 10. PWM_SIGX Timing	23
Figure 11. Control Port Timing - I ² C	24
Figure 12. Typical SYS_CLK Input Clocking Configuration	26
Figure 13. Typical Crystal Oscillator Clocking Configuration	27
Figure 14. Digital Signal Flow	29
Figure 15. De-Emphasis Filter	31
Figure 16. Bi-Quad Filter Architecture	33
Figure 17. Peak Signal Detection & Limiting	37

Figure 18. Foldback Process	39
Figure 19. 2-Channel Full-Bridge PWM Output Delay	46
Figure 20. 3-Channel PWM Output Delay	46
Figure 21. Typical SYS_CLK Input Clocking Configuration	49
Figure 22. Hardware Mode PWM Output Delay	50
Figure 23. Hardware Mode Digital Signal Flow	51
Figure 24. Foldback Process	52
Figure 25. Output Filter - Half-Bridge	54
Figure 26. Output Filter - Full-Bridge	55
Figure 27. Recommended Unity Gain Input Filter	56
Figure 28. Recommended 2 V _{RMS} Input Filter	56
Figure 29. I ² S Serial Audio Formats	57
Figure 30. Left-Justified Serial Audio Formats	57
Figure 31. Right-Justified Serial Audio Formats	58
Figure 32. Control Port Timing, I ² C Write	59
Figure 33. Control Port Timing, I ² C Read	59

LIST OF TABLES

Table 1. I/O Power Rails	12
Table 2. Bass Shelving Filter Corner Frequencies	31
Table 3. Treble Shelving Filter Corner Frequencies	32
Table 4. Bass Management Cross-Over Frequencies	35
Table 5. 2-Way Cross-Over Frequencies	41
Table 6. Auxiliary Serial Port Data Output	42
Table 7. PWM Power Output Configurations	43
Table 8. PWM Logic-Level Output Configurations	44
Table 9. PWM Output Switching Rates and Quantization Levels	47
Table 10. SYS_CLOCK Frequency Selection	49
Table 11. Input Source Selection	50
Table 12. Serial Audio Interface Format Selection	50
Table 13. Thermal Foldback Enable Selection	52
Table 14. PWM Output Switching Rates and Quantization Levels	53
Table 15. Low-Pass Filter Components - Half-Bridge	54
Table 16. DC-Blocking Capacitors Values - Half-Bridge	54
Table 17. Low-Pass Filter Components - Full-Bridge	55
Table 18. Input Source Selection	60

1. PIN DESCRIPTIONS - SOFTWARE MODE

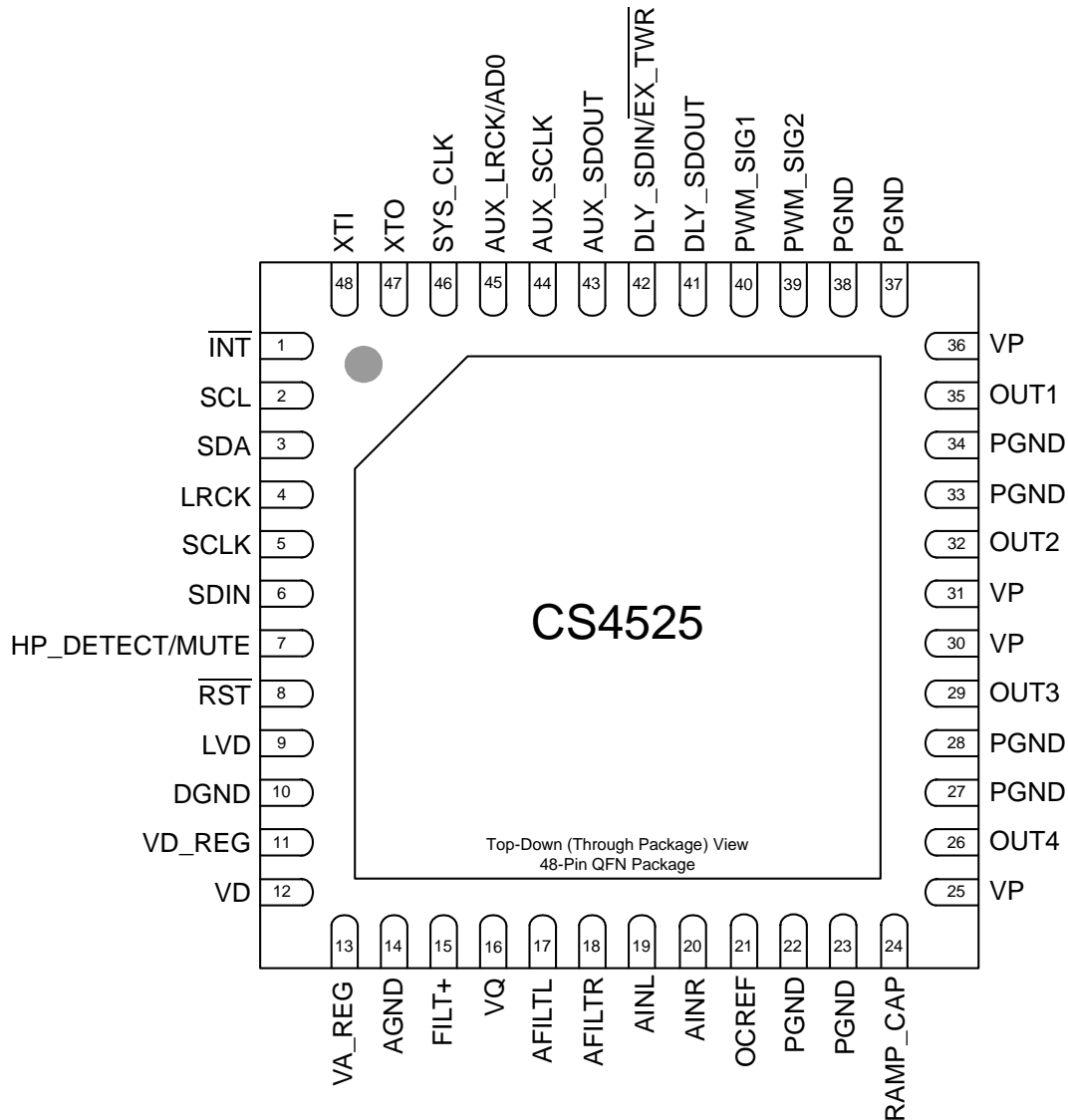

Pin Name	Pin #	Pin Description
$\overline{\text{INT}}$	1	Interrupt (Output) - Indicates an interrupt condition has occurred.
SCL	2	Serial Control Port Clock (Input) - Serial clock for the I ² C control port.
SDA	3	Serial Control Data (Input/Output) - Bi-directional data I/O for the I ² C control port.
LRCK	4	Left Right Clock (Input) - Determines which channel, Left or Right, is currently active on the serial audio data line.
SCLK	5	Serial Clock (Input) - Serial bit clock for the serial audio interface.
SDIN	6	Serial Audio Data Input (Input) - Input for two's complement serial audio data.
HP_DETECT/ MUTE	7	Headphone Detect / Mute (Input) - Headphone detection or mute input signal.
$\overline{\text{RST}}$	8	Reset (Input) - The device enters a low power mode and all internal registers are reset to their default settings when this pin is driven low.

LVD	9	VD Voltage Level Indicator (Input) - Identifies the voltage level attached to VD. When applying 5.0 V to VD, LVD must be connected to VD. When applying 2.5 V or 3.3 V to VD, LVD must be DGND.
DGND	10	Digital Ground (Input) - Ground for the internal logic and digital I/O.
VD_REG	11	Core Logic Power (Output) - Internally generated low voltage power supply for digital logic.
VD	12	Power (Input) - Positive power supply for the internal regulators and digital I/O.
VA_REG	13	Analog Power (Output) - Internally generated positive power for the analog section and I/O.
AGND	14	Analog Ground (Input) - Ground reference for the internal analog section and I/O.
FILT+	15	Positive Voltage Reference (Output) - Positive reference voltage for the internal ADC sampling circuits.
VQ	16	Common Mode Voltage (Output) - Filter connection for internal common mode voltage.
AFILT	17	Antialias Filter Connection (Output) - Antialias filter connection for ADC inputs.
AFILTR	18	
AINL	19	Analog Input (Input) - The full-scale input level is specified in the ADC Analog Characteristics specification table.
AINR	20	
OCREF	21	Over Current Reference Setting (Input) - Sets the reference for over current detection.
PGND	22,23	Power Ground (Input) - Ground for the individual output power half-bridge devices.
	27,28	
	33,34	
	37,38	
RAMP_CAP	24	Output Ramp Capacitor (Input) - Used for shaping the output ramp time for half-bridge configured outputs.
VP	25,30, 31,36	High Voltage Power (Input) - High voltage power supply for the individual half-bridge devices.
OUT4	26	PWM Output (Output) - Amplified PWM power outputs.
OUT3	29	
OUT2	32	
OUT1	35	
PWM_SIG2	39	PWM Output (Output) - PWM switching signals.
PWM_SIG1	40	
DLY_SDOUT	41	Delay Serial Audio Data Out (Output) - Output for two's complement serial audio data. Default pin configuration.
DLY_SDIN/ EX_TWR	42	Delay Serial Audio Data Input (Input) - Input for two's complement serial audio data. Default pin configuration.
		External Thermal Warning (Input) - Input for an external thermal warning signal. Configurable via the I ² C control port.
AUX_SDOUT	43	Auxiliary Port Serial Audio Data Out (Output) - Output for two's complement auxiliary port serial data.
AUX_SCLK	44	Auxiliary Port Serial Clock (Output) - Serial clock for the auxiliary port serial interface.
AUX_LRCK/ AD0	45	Auxiliary Port Left Right Clock (Output) - Determines which channel, Left or Right, is currently active on the serial audio data line.
		AD0 (Input) - Sets the LSB of the I ² C device address. Sensed on the release of $\overline{\text{RST}}$.
SYS_CLK	46	System Clock (Input/Output) - Clock source for the internal logic, processing, and modulators.
XTO	47	Crystal Oscillator Output (Output) - Crystal oscillator driver output.
XTI	48	Crystal Oscillator Input (Input) - Crystal oscillator driver input.

2. PIN DESCRIPTIONS - HARDWARE MODE

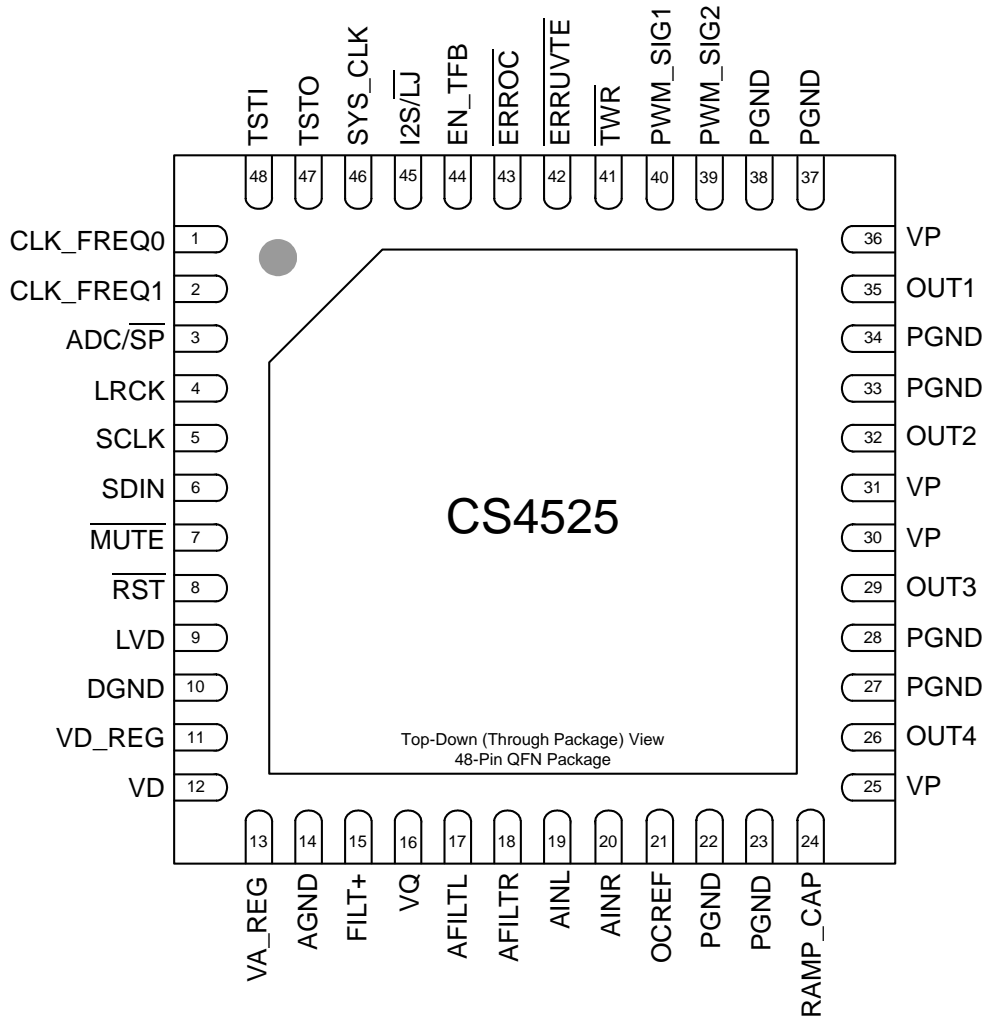

Pin Name	Pin #	Pin Description
CLK_FREQ0	1	Clock Frequency (Input) - Determines the frequency of the clock expected to be driven into the SYS_CLK pin.
CLK_FREQ1	2	
ADC/SP	3	ADC/Serial Port (Input) - Selects between the Analog to Digital Converter and the Serial Port for audio input. Selects the ADC when high or the serial port when low.
LRCK	4	Left Right Clock (Input) - Determines which channel, Left or Right, is currently active on the serial audio data line.
SCLK	5	Serial Clock (Input) - Serial bit clock for the serial audio interface.
SDIN	6	Serial Audio Data Input (Input) - Input for two's complement serial audio data.
MUTE	7	Mute (Input) - Mute input signal.
RST	8	Reset (Input) - The device enters a low power mode and all internal registers are reset to their default settings when this pin is driven low.

LVD	9	VD Voltage Level Indicator (Input) - Identifies the voltage level attached to VD. When applying 5.0 V to VD, LVD must be connected to VD. When applying 2.5 V or 3.3 V to VD, LVD must be connected to DGND.
DGND	10	Digital Ground (Input) - Ground for the internal logic and I/O.
VD_REG	11	Core Logic Power (Output) - Internally generated low voltage power supply for digital logic.
VD	12	Digital Power (Input) - Positive power supply for the internal regulators and digital I/O.
VA_REG	13	Analog Power (Output) - Internally generated positive power for the analog section and I/O.
AGND	14	Analog Ground (Input) - Ground reference for the internal analog section and I/O.
FILT+	15	Positive Voltage Reference (Output) - Positive reference voltage for the internal ADC sampling circuits.
VQ	16	Common Mode Voltage (Output) - Filter connection for internal common mode voltage.
AFILT	17	Antialias Filter Connection (Output) - Antialias filter connection for ADC inputs.
AFILTR	18	
AINL	19	Analog Input (Input) - The full-scale input level is specified in the ADC Analog Characteristics specification table.
AINR	20	
OCREF	21	Over Current Reference Setting (Input) - Sets the reference for over current detection.
PGND	22,23	Power Ground (Input) - Ground for the individual output power half-bridge devices.
	27,28	
	33,34	
	37,38	
RAMP_CAP	24	Output Ramp Capacitor (Input) - Used for shaping the output ramp time for half-bridge configured outputs.
VP	25,30, 31,36	High Voltage Power (Input) - High voltage power supply for the individual half-bridge devices.
OUT4	26	PWM Output (Output) - Amplified PWM power outputs.
OUT3	29	
OUT2	32	
OUT1	35	
PWM_SIG2	39	PWM Output (Output) - PWM switching signals.
PWM_SIG1	40	
TWR	41	Thermal Warning Output (Output) - Thermal warning output.
ERRUVTE	42	Thermal and Undervoltage Error Output (Output) - Error flag for thermal shutdown and undervoltage.
ERROC	43	Overcurrent Error Output (Output) - Overcurrent error flag.
EN_TFB	44	Enable Thermal Feedback (Input) - Enables the thermal foldback feature when high.
I2S/LJ	45	I²S/Left Justified (Input) - Selects between I ² S and Left-Justified data format for the serial input and output ports. Selects I ² S when high and LJ when low.
SYS_CLK	46	System Clock (Input/Output) - Clock source for the delta-sigma modulators.
TSTO	47	Test Output (Output) - This pin is an output used for the crystal oscillator driver available only in software mode. It must be left unconnected for normal hardware mode operation.
TSTI	48	Test Input (Input) - This pin is an input used for the crystal oscillator driver available only in software mode. It must be tied to digital ground for normal hardware mode operation.

2.1 Digital I/O Pin Characteristics

The logic level for each input is set by its corresponding power supply and should not exceed the maximum ratings.

Power Supply	Pin Number	Pin Name	I/O	Driver	Receiver
Software Mode					
VD	1	$\overline{\text{INT}}$	Output	2.5 V-5.0 V, Open Drain	
	2	SCL	Input	-	2.5 V-5.0 V, with Hysteresis
	3	SDA	Input/Output	2.5 V-5.0 V, Open Drain	2.5 V-5.0 V, with Hysteresis
	7	HP_DETECT	Input	-	2.5 V-5.0 V
		MUTE	Input	-	2.5 V-5.0 V
	41	DLY_SDOOUT	Output	2.5 V-5.0 V, CMOS	-
	42	DLY_SDIN	Input	-	2.5 V-5.0 V
		EX_TWR	Input	-	2.5 V-5.0 V
	43	AUX_SDOOUT	Output	2.5 V-5.0 V, CMOS	-
44	AUX_SCLK	Output	2.5 V-5.0 V, CMOS	-	
45	AUX_LRCK	Output	2.5 V-5.0 V, CMOS	-	
Hardware Mode					
VD	1	SEL_OSC0	Input	-	2.5 V-5.0 V
	2	SEL_OSC1	Input	-	2.5 V-5.0 V
	3	ADC/ $\overline{\text{SP}}$	Input	-	2.5 V-5.0 V
	7	$\overline{\text{MUTE}}$	Input	-	2.5 V-5.0 V
	41	$\overline{\text{TWR}}$	Output	2.5 V-5.0 V, Open Drain	-
	42	$\overline{\text{ERRUVTE}}$	Output	2.5 V-5.0 V, Open Drain	-
	43	$\overline{\text{ERROC}}$	Output	2.5 V-5.0 V, Open Drain	-
	44	EN_TFB	Input	-	2.5 V-5.0 V
	45	I ² S/ $\overline{\text{LJ}}$	Input	-	2.5 V-5.0 V
All Modes					
VD	4	LRCK	Input	-	2.5 V-5.0 V
	5	SCLK	Input	-	2.5 V-5.0 V
	6	SDIN	Input	-	2.5 V-5.0 V
	8	$\overline{\text{RST}}$	Input	-	2.5 V-5.0 V
	9	LVD	Input	-	2.5 V-5.0 V
	46	SYS_CLK	Input/Output	2.5 V-5.0 V, CMOS	2.5 V-5.0 V
VD_REG		PWM_SIG1	Output	2.5 V, CMOS	-
		PWM_SIG2	Output	2.5 V, CMOS	-
VP		OUT1-OUT4	Output	10.5 V-18.0 V Power MOSFET	-

Table 1. I/O Power Rails

3. TYPICAL CONNECTION DIAGRAMS

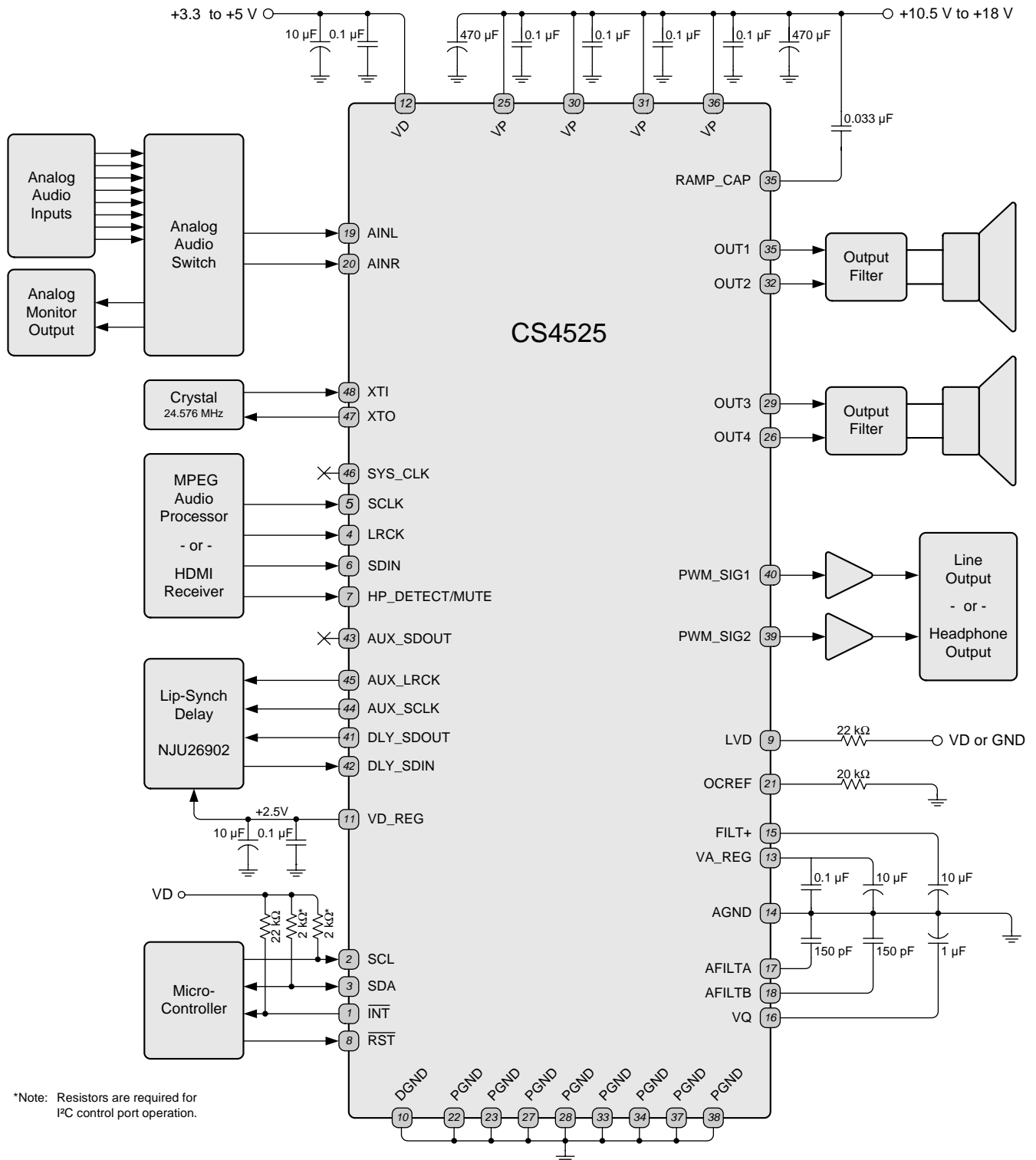

*Note: Resistors are required for I²C control port operation.

Figure 1. Typical Connection Diagram - Software Mode

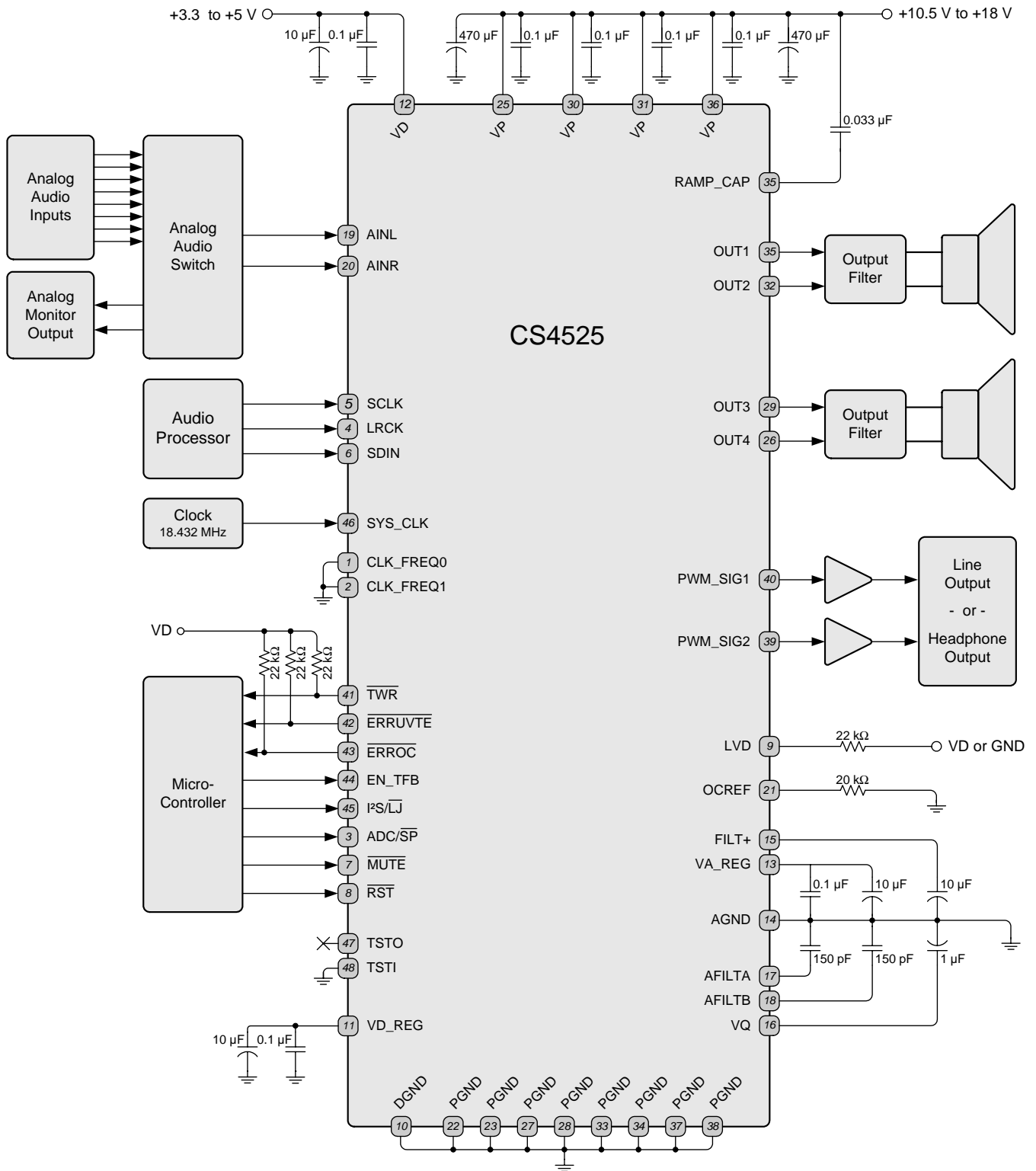
Figure 2. Typical Connection Diagram - Hardware Mode

4. TYPICAL SYSTEM CONFIGURATION DIAGRAMS

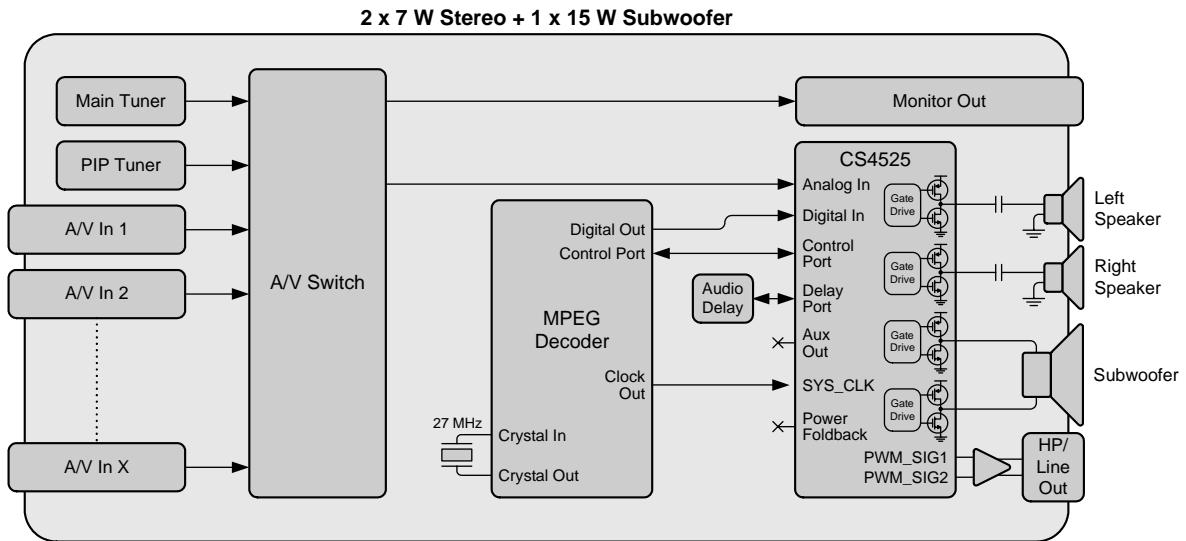

Figure 3. Typical System Configuration 1

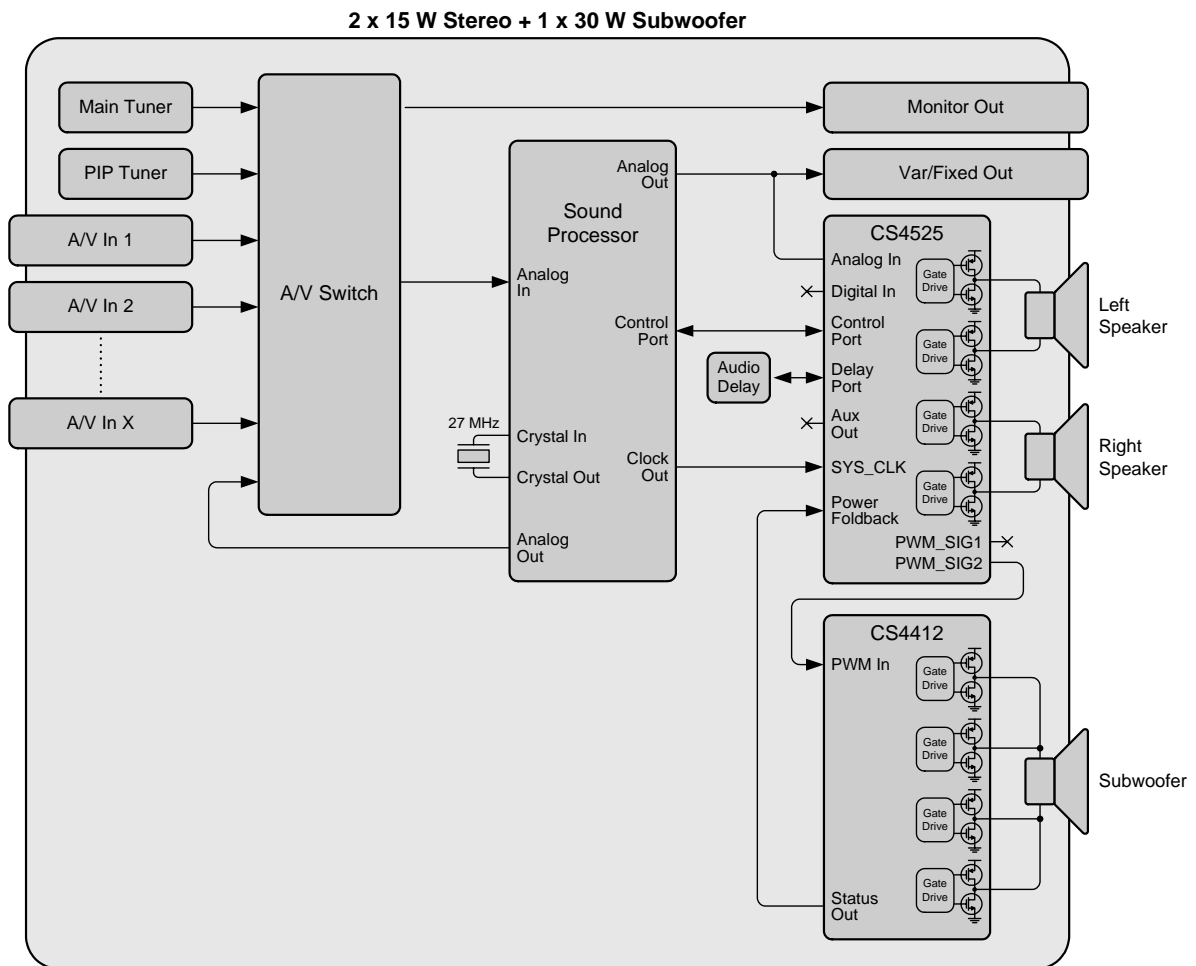

Figure 4. Typical System Configuration 2

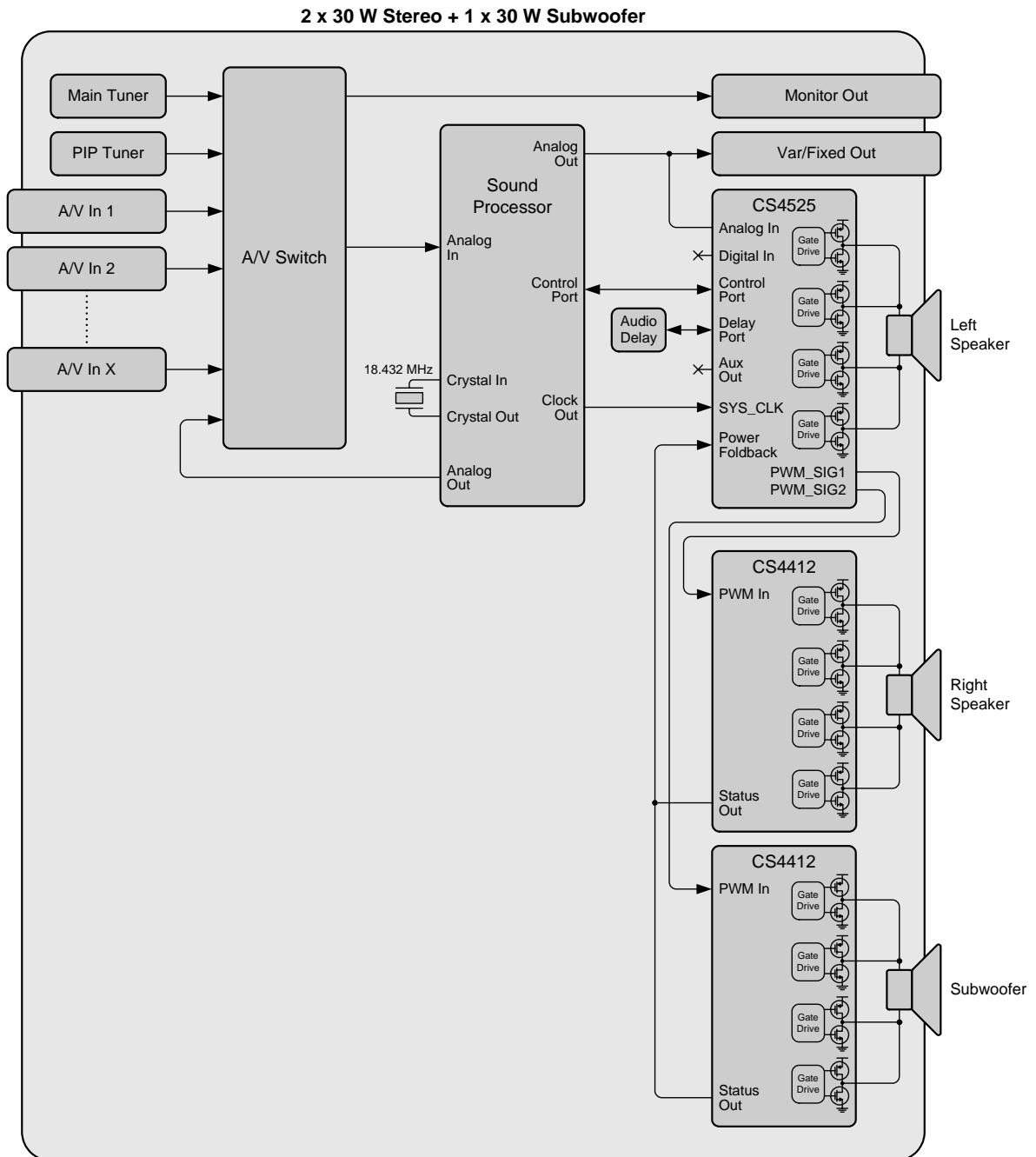

Figure 5. Typical System Configuration 3

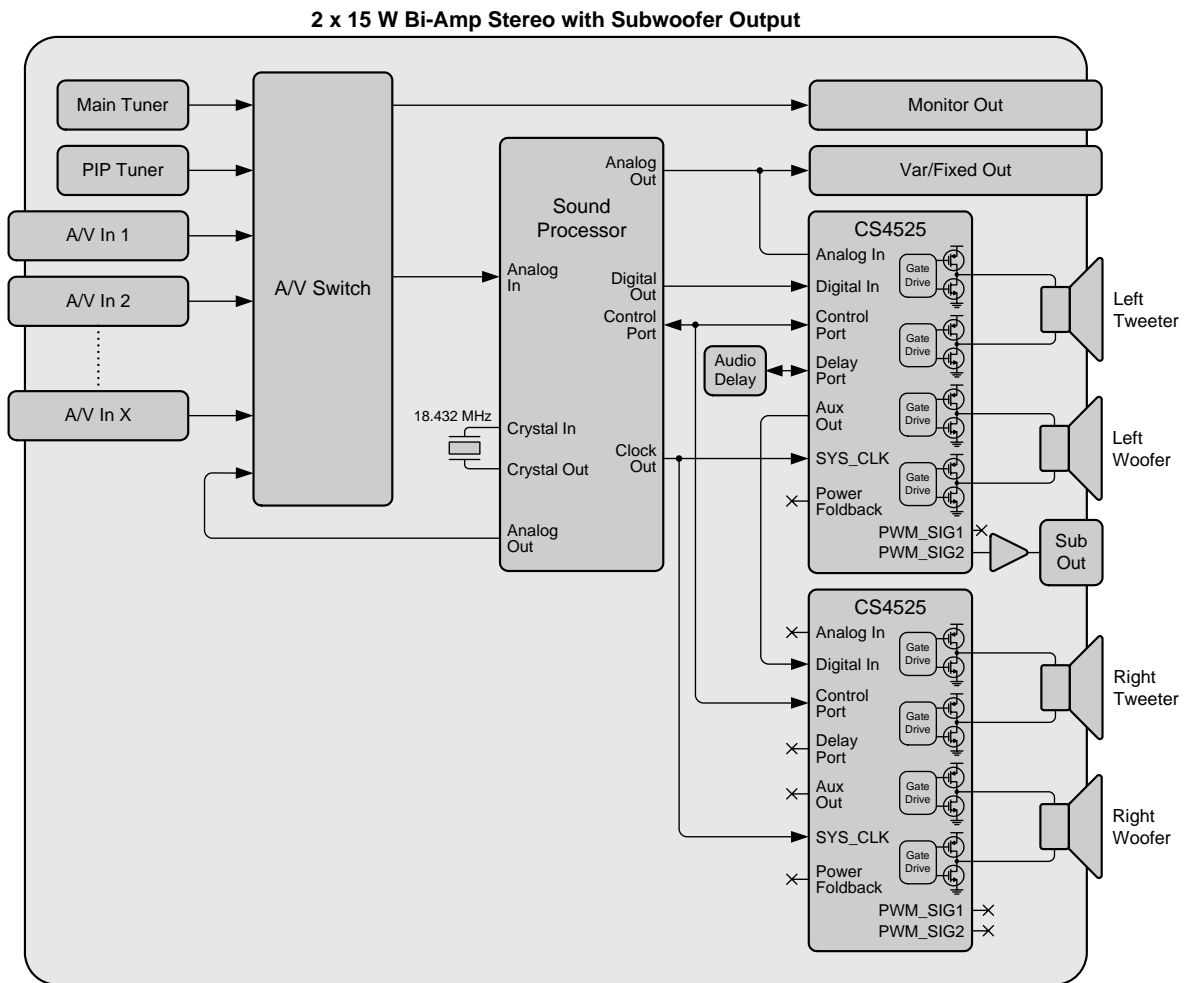

Figure 6. Typical System Configuration 4

5. CHARACTERISTIC AND SPECIFICATION TABLES

(All Min/Max characteristics and specifications are guaranteed over the Specified Operating Conditions. Typical performance characteristics and specifications are derived from measurements taken at nominal supply voltages and $T_A = 25^\circ \text{C}$.)

SPECIFIED OPERATING CONDITIONS

(AGND = DGND=PGND=0 V, all voltages with respect to ground.)

Parameters	Symbol	Min	Nom	Max	Units
DC Power Supply					
Digital and Analog Core	VD	2.375	2.5	2.625	V
	VD	3.135	3.3	3.465	V
	VD	4.75	5.0	5.25	V
Amplifier Outputs	VP	10.5	-	18.0	V
Temperature					
Ambient Temperature	T_A	-10	-	+70	$^\circ\text{C}$
Junction Temperature	T_J		-	+150	$^\circ\text{C}$

ABSOLUTE MAXIMUM RATINGS

(AGND = DGND = PGND = 0 V; all voltages with respect to ground.)

Parameters	Symbol	Min	Max	Units
DC Power Supply	VP	-0.3	20.0	V
PWM Outputs	VP	-0.3	20.0	V
Digital and Analog Core	VD	-0.3	6.0	V
Input Current	I_{in}	-	± 10	mA
Analog Input Voltage	V_{INA}	AGND-0.7	$VA_REG + 0.7$	V
Digital Input Voltage	V_{IND}	-0.3	$VD + 0.4$	V
Ambient Operating Temperature - Power Applied	T_A	-20	+85	$^\circ\text{C}$
Commercial	T_A	-20	+85	$^\circ\text{C}$
Storage Temperature	T_{stg}	-65	+150	$^\circ\text{C}$

- Notes:**
1. Operation at or beyond these limits may result in permanent damage to the device. Normal operation is not guaranteed at these extremes.
 2. Any pin except supplies. Transient currents of up to ± 100 mA on the analog input pins will not cause SCR latch-up.
 3. The maximum over/under voltage is limited by the input current.

ANALOG INPUT CHARACTERISTICS

Test Conditions (unless otherwise specified): Input Signal: 1 kHz sine wave through the recommended passive input filter shown in [Figure 27 on page 56](#); Sample Frequency = 48 kHz, 10 Hz to 20 kHz Measurement Bandwidth. Power outputs in power-down state (PDnOut1 = 1, PDnOut2 = 1, PDnOut3/4 = 1).

Parameter		Min	Typ	Max	Unit
Analog In to ADC					
Dynamic Range (Note 4)	A-weighted	90	95	-	dB
	unweighted	87	92	-	dB
Total Harmonic Distortion + Noise	-1 dB	-	-88	-82	dB
	-20 dB	-	-75	-	dB
	-60 dB	-	-35	-	dB
DC Accuracy					
Interchannel Gain Mismatch		-	0.1	-	dB
Gain Drift		-	±100	-	ppm/°C
Input					
Interchannel Isolation		-	90	-	dB
Full-scale Input Voltage		1.96	2.18	2.40	V _{pp}
Input Impedance	(Note 5)	40	-	-	kΩ

- Notes:**
4. Referred to the typical full-scale voltage.
 5. Measured between AINx and AGND.

ADC DIGITAL FILTER CHARACTERISTICS

Parameter		Min	Typ	Max	Unit
Passband (Frequency Response) (Note 6)	to -0.1 dB corner	0	-	0.4948	F _s
Passband Ripple		-0.09	-	0	dB
Stopband	(Note 6)	0.6677	-	-	F _s
Stopband Attenuation		48.4	-	-	dB
Total Group Delay		-	2.7/F _s	-	s
High-Pass Filter Characteristics					
Frequency Response	-3.0 dB	-	3.7	-	Hz
	-0.13 dB	-	24.2	-	Hz
Phase Deviation	20 Hz	-	10	-	Deg
Passband Ripple		-	-	0.17	dB
Filter Settling Time		-	10 ⁵ /F _s	0	s

- Notes:**
6. Filter response is clock dependent and scales with the ADC sampling frequency (F_s). With a 27.000 MHz or 24.576 MHz XTAL/SYS_CLK, F_s is equal to the applied clock divided by 512. With an 18.432 MHz XTAL/SYS_CLK, F_s is equal to the applied clock divided by 384.

PWM POWER OUTPUT CHARACTERISTICS

AGND = DGND = PGND = 0 V; All voltages with respect to ground; VP = 18 V; $R_L = 8 \Omega$ for full-bridge, $R_L = 4 \Omega$ for half-bridge and parallel full-bridge; PWM Switch Rate = 384 kHz; 10 Hz to 20 kHz Measurement Bandwidth; Performance measurements taken with a full scale 997 Hz sine wave and AES17 filter; Unless otherwise specified.

Parameters	Symbol	Conditions	Min	Typ	Max	Units
Power Output per Channel						
Stereo Full-Bridge	P _O	THD+N < 10%	-	15	-	W
		THD+N < 1%	-	12	-	W
Half-Bridge		THD+N < 10%	-	7	-	W
		THD+N < 1%	-	5.5	-	W
Parallel Full-Bridge		THD+N < 10%	-	30	-	W
		THD+N < 1%	-	23.5	-	W
Total Harmonic Distortion + Noise						
Stereo Full-Bridge	THD+N	P _O = 1 W	-	0.1	-	%
		P _O = 0 dBFS = 11.3 W	-	0.3	-	%
Half-Bridge		P _O = 1 W	-	0.1	-	%
		P _O = 0 dBFS = 5.0 W	-	0.3	-	%
Parallel Full-Bridge		P _O = 1 W	-	0.1	-	%
		P _O = 0 dBFS = 22.6 W	-	0.3	-	%
Dynamic Range						
Stereo Full-Bridge	DYR	P _O = -60 dBFS, A-Weighted	-	102	-	dB
		P _O = -60 dBFS, Unweighted	-	99	-	dB
Half-Bridge		P _O = -60 dBFS, A-Weighted	-	102	-	dB
		P _O = -60 dBFS, Unweighted	-	99	-	dB
Parallel Full-Bridge		P _O = -60 dBFS, A-Weighted	-	102	-	dB
		P _O = -60 dBFS, Unweighted	-	99	-	dB
MOSFET On Resistance	R _{DS(ON)}	I _d = 0.5 A, T _J = 50°C	-	518	615	mΩ
Efficiency	h	P _O = 2 x 11.3 W, R _L = 8 Ω	-	85	-	%
Minimum Output Pulse Width	PW _{min}	No Load	-	50	-	ns
Rise Time of OUTx	t _r	Resistive Load	-	20	-	ns
Fall Time of OUTx	t _f	Resistive Load	-	20	-	ns
PWM Output Over-Current Error Trip Point	I _{CE}	T _A = 25°C, OCREF = 20 kΩ	2.0	-	-	A
Junction Thermal Warning Trip Point	T _{TW}		-	120	-	°C
Junction Thermal Error Trip Point	T _{TE}		-	140	-	°C
VP Under-Voltage Error Trip Point	V _{UV}	T _A = 25°C	4	-	-	V
Ramp-Up Time - Half-Bridge Configuration	T _{RU}	Capacitor = 1000 μF	-	0.8	-	s
Ramp-Down Time- Half-Bridge Configuration	T _{RD}	Capacitor = 1000 μF	-	50	-	s

SERIAL AUDIO INPUT PORT SWITCHING SPECIFICATIONS

Inputs: Logic 0 = DGND; Logic 1 = VD

Parameters	Symbol	Min	Nominal	Max	Units
Supported Input Sample Rates	F_{SI}	28.5	32	35.2	kHz
		39.5	44.1	52.8	
		39.5	48	52.8	
		86.4	96	105.6	
LRCK Duty Cycle		45	-	55	%
SCLK Frequency	Single-Speed Mode	-	-	$128 \cdot F_{SI}$	Hz
	Double-Speed Mode	-	-	$64 \cdot F_{SI}$	Hz
SCLK Duty Cycle		45	-	55	%
LRCK Setup Time Before SCLK Rising Edge	$t_{s(LK-SK)}$	40	-	-	ns
SDIN Setup Time Before SCLK Rising Edge	$t_{s(SD-SK)}$	25	-	-	ns
SDIN Hold Time After SCLK Rising Edge	t_h	10	-	-	ns
RST pin Low Pulse Width	(Note 7)	1	-	-	ms

Notes: 7. After powering up the CS4525, \overline{RST} should be held low until the power supplies and clocks are stable.

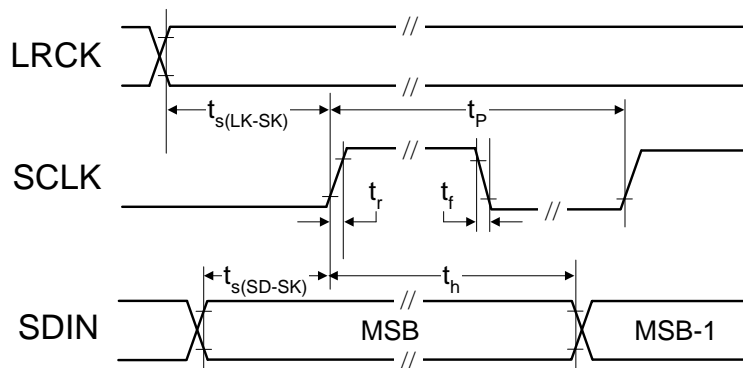

Figure 7. Serial Audio Input Port Timing

AUX SERIAL AUDIO I/O PORT SWITCHING SPECIFICATIONS

Inputs: Logic 0 = DGND; Logic 1 = VD; AUX_SDOOUT & DLY_SDOOUT $C_L = 15$ pF. (Note 8)

Parameters		Symbol	Min	Typ	Max	Units
Input Source: Analog Inputs (Internal ADC)						
Output Sample Rate	ClkFreq[1:0] = '00'	F_{SO}	-	$F_{CLK}/384$	-	Hz
	ClkFreq[1:0] = '01'		-	$F_{CLK}/512$	-	Hz
	ClkFreq[1:0] = '10'		-	$F_{CLK}/512$	-	Hz
AUX_LRCK Duty Cycle			-	50	-	%
AUX_LRCK Period			-	$1/F_{SO}$	-	s
AUX_SCLK Frequency	ClkFreq[1:0] = '00'	F_{SCLKO}	-	$48 \cdot F_{SO}$	-	Hz
	ClkFreq[1:0] = '01'		-	$64 \cdot F_{SO}$	-	Hz
	ClkFreq[1:0] = '10'		-	$64 \cdot F_{SO}$	-	Hz
AUX_SCLK Duty Cycle			-	50	-	%
AUX_SCLK Period			-	$1/F_{SCLKO}$	-	s
Input Source: Serial Audio Input Port						
Output Sample Rate	$F_{S-In} = 32\text{kHz}, 44.1\text{ kHz}, 48\text{ kHz}$	F_{SO}	-	F_{SI}	-	Hz
	$F_{S-In} = 96\text{ kHz}$		-	$F_{SI}/2$	-	Hz
AUX_LRCK Duty Cycle	(Note 10)		45	-	55	%
AUX_LRCK Period	(Note 9, 10)		$T_{SI} - T_{CLK}$	T_{SI}	$T_{SI} + T_{CLK}$	s
AUX_SCLK Frequency	$F_{S-In} = 32\text{kHz}, 44.1\text{ kHz}, 48\text{ kHz}$		-	F_{SCLKI}	-	Hz
	$F_{S-In} = 96\text{ kHz}$		-	$F_{SCLKI}/2$	-	Hz
AUX_SCLK Duty Cycle			30	-	70	%
AUX_SCLK Period	$F_{S-In} = 32\text{kHz}, 44.1\text{ kHz}, 48\text{ kHz}$		$T_{SCLKI} - T_{CLK}$	T_{SCLKI}	$T_{SCLKI} + T_{CLK}$	s
	$F_{S-In} = 96\text{ kHz}$		$2 \cdot T_{SCLKI} - T_{CLK}$	$2 \cdot T_{SCLKI}$	$2 \cdot T_{SCLKI} + T_{CLK}$	s
Input Source: Analog Inputs or Serial Audio Input Port						
AUX_LRCK Rising Edge to AUX_SCLK Falling Edge		t_{LTSF}	-	-	20	ns
AUX_SCLK Rising Edge to Data Output Valid		t_{SRDV}	-	-	$T_{CLK} + 20$	ns
DLY_SDIN Setup Time Before AUX_SCLK Rising Edge		t_{DIS}	25	-	-	ns
DLY_SDIN Hold Time After AUX_SCLK Rising Edge		t_{DIH}	10	-	-	ns

- Notes:**
8. F_{CLK} is the frequency of the applied crystal or the input SYS_CLK signal. $T_{CLK} = 1/F_{CLK}$.
 9. F_{SI} is the frequency of the input LRCK signal. $T_{SI} = 1/F_{SI}$
 10. May vary during normal operation.
 11. F_{SCLKI} is the frequency of the input SCLK signal. $T_{SCLKI} = 1/F_{SCLKI}$.

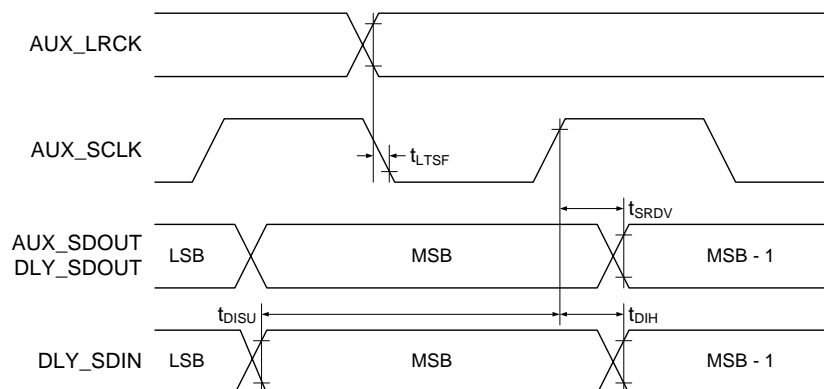

Figure 8. AUX Serial Port Interface Master Mode Timing

XTI SWITCHING SPECIFICATIONS

Parameter	Symbol	Min	Typ	Max	Unit
External Crystal Operating Frequency (Note 12)	ClkFreq[1:0] = '00'	17.510	18.432	19.354	MHz
	ClkFreq[1:0] = '01'	23.347	24.576	25.805	MHz
	ClkFreq[1:0] = '10'	25.650	27.000	28.350	MHz
XTI Duty Cycle		45	50	55	%

Notes: 12. See "Clock Frequency (ClkFreq[1:0])" on page 64.

SYS_CLK SWITCHING SPECIFICATIONS

Input: Logic 0 = DGND; Logic 1 = VD, SYS_CLK Output: $C_L = 20$ pF.

Parameter	Symbol	Min	Typ	Max	Unit
External Clock Operating Frequency (Note 12)	ClkFreq[1:0] = '00'	17.510	18.432	19.354	MHz
	ClkFreq[1:0] = '01'	23.347	24.576	25.805	MHz
	ClkFreq[1:0] = '10'	25.650	27.000	28.350	MHz
Rising Edge \overline{RST} to start of SYS_CLK	t_{sclko}		$1024 \cdot t_{sclki}$		
SYS_CLK Period	t_{sclki}	37.04	---	54.25	ns
SYS_CLK Duty Cycle		45	50	55	%
SYS_CLK high time	t_{clkih}	16.67	---	29.84	ns
SYS_CLK low time	t_{clkil}	16.67	---	29.84	ns

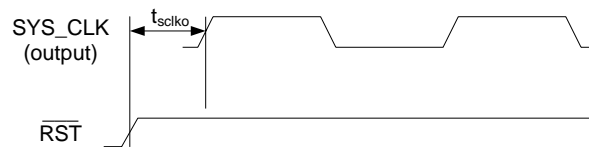

Figure 9. SYS_CLK Timing from Reset

PWM_SIGX SWITCHING SPECIFICATIONS

Parameter	Symbol	Min	Typ	Max	Unit
PWM_SIGx Period	t_{pwm}	2.60	-	1.18	μ s
Rise Time of PWM_SIGx	t_r	-	2.1	-	ns
Fall Time of PWM_SIGx	t_f	-	1.4	-	ns

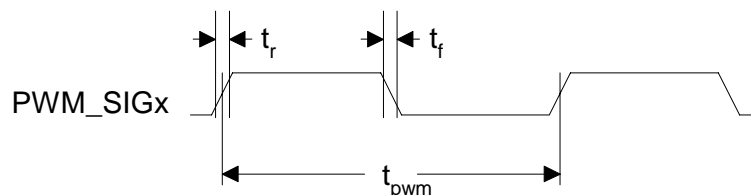

Figure 10. PWM_SIGX Timing

I²C CONTROL PORT SWITCHING SPECIFICATIONS

Inputs: Logic 0 = DGND; Logic 1 = VD; SDA C_L = 30 pF

Parameter	Symbol	Min	Max	Unit
SCL Clock Frequency	f _{scl}	-	100	kHz
RST Rising Edge to Start	t _{irs}	500	-	ns
Bus Free Time Between Transmissions	t _{buf}	4.7	-	μs
Start Condition Hold Time (prior to first clock pulse)	t _{hdst}	4.0	-	μs
Clock Low time	t _{low}	4.7	-	μs
Clock High Time	t _{high}	4.0	-	μs
Setup Time for Repeated Start Condition	t _{sust}	4.7	-	μs
SDA Hold Time from SCL Falling (Note 13)	t _{hdd}	0	-	μs
SDA Setup time to SCL Rising	t _{sud}	250	-	ns
Rise Time of SCL and SDA	t _{rc}	-	1	μs
Fall Time SCL and SDA	t _{fc}	-	300	ns
Setup Time for Stop Condition	t _{susp}	4.7	-	μs
Acknowledge Delay from SCL Falling	t _{ack}	300	1000	ns

Notes: 13. Data must be held for sufficient time to bridge the transition time, t_{fc}, of SCL.

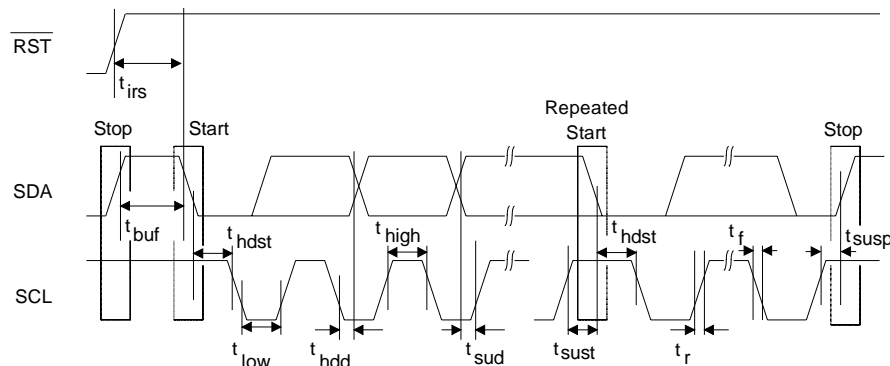

Figure 11. Control Port Timing - I²C

DC ELECTRICAL CHARACTERISTICS

AGND = DGND = PGND = 0 V; All voltages with respect to ground; PWM switch rate = 384 kHz; Unless otherwise specified.

Parameters	Min	Typ	Max	Units
Normal Operation (Note 14)				
Power Supply Current VD = 3.3 V	-	20	-	mA
Power Dissipation VD = 3.3 V	-	66	-	mW
Power-Down Mode (Note 15)				
Power Supply Current VD = 3.3 V	-	4.3	-	mA
VD_REG Characteristics				
Nominal Voltage	2.25	2.5	2.75	V
DC current source	-	-	3	mA
VA_REG Characteristics				
Nominal Voltage	2.25	2.5	2.75	V
DC current source	-	-	1	mA
VQ Characteristics				
Nominal Voltage	-	0.5•VA_REG	-	V
Output Impedance	-	23	-	kΩ
DC current source/sink (Note 16)	-	-	10	μA
Filt+ Nominal Voltage	-	VA_REG	-	V
Power Supply Rejection Ratio (Note 17)	1 kHz	60	-	dB
	60 Hz	40	-	dB

- Notes:**
- Normal operation is defined as $\overline{RST} = HI$.
 - Power-Down Mode is defined as $\overline{RST} = LOW$ with all input lines held static.
 - The DC current drain represents the allowed current from the VQ pin due to typical leakage through the electrolytic de-coupling capacitors.
 - Valid with the recommended capacitor values on FILT+ and VQ. Increasing the capacitance will increase the PSRR.

DIGITAL INTERFACE SPECIFICATIONS

AGND = DGND = PGND = 0 V; All voltages with respect to ground; Unless otherwise specified.

Parameters	Symbol	Min	Max	Units
High-Level Input Voltage	V _{IH}	0.7•VD_REG	VD	V
Low-Level Input Voltage	V _{IL}	-	0.20•VD_REG	V
High-Level Output Voltage I _o =2 mA	V _{OH}	0.90•VD	-	V
Low-Level Output Voltage I _o =2 mA	V _{OL}	-	0.2	V
Input Leakage Current	I _{in}	-	±10	uA
Input Capacitance		-	8	pF

6. APPLICATIONS

6.1 Software Mode

Maximum device flexibility and features are available when the CS4525 is used in software mode. The available features are described in the following sections. All device configuration is achieved via the I²C control port as described in the [I²C Control Port Description and Timing](#) section on [page 59](#).

6.1.1 System Clocking

In software mode, the CS4525 can be clocked by a stable external clock source input on the SYS_CLK pin or by a clock internally generated through the use of its internal oscillator driver circuit in conjunction with an external crystal oscillator. The device automatically selects which of these clocks to use immediately after the release of \overline{RST} .

The internal clock is used to synchronize the input serial audio signals with the internal clock domain and to clock the internal digital processing, sample-rate converter, and PWM modulators. It is also used to determine the sample rate of the serial audio input signals in order to automatically configure the various internal filter coefficients.

To ensure proper operation, the CS4525 must be informed of the nominal frequency of the supplied SYS_CLK signal or the attached crystal via the ClkFreq[1:0] bits in the Clock Config register. These bits must be set to the appropriate value before the PDnAll bit is cleared to initiate a power-up sequence. See the [SYS_CLK Switching Specifications](#) and [XTI Switching Specifications](#) tables on [page 23](#) for complete input frequency range specifications.

Referenced Control	Register Location
ClkFreq[1:0].....	"Clock Frequency (ClkFreq[1:0])" on page 64
PDnAll	"Power Down (PDnAll)" on page 81

6.1.1.1 SYS_CLK Input Clock Mode

If an input clock is detected on the SYS_CLK pin and oscillations are not detected on the XTI pin following the release of \overline{RST} , the device will automatically use the SYS_CLK input as its clock source. The applied SYS_CLK clock signal must oscillate within the frequency ranges specified in the SYS_CLK switching specifications table on [page 23](#). In this mode, XTI should be connected to ground and XTO should be left unconnected.

[Figure 12](#) below demonstrates a typical clocking configuration using the SYS_CLK input.

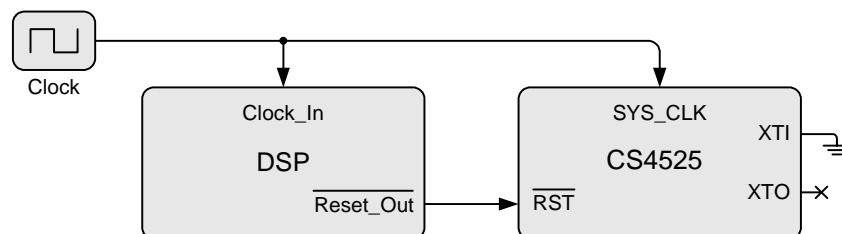

Figure 12. Typical SYS_CLK Input Clocking Configuration

6.1.1.2 Crystal Oscillator Mode

To use an external crystal in conjunction with the internal crystal driver, a 20 pF fundamental mode parallel resonant crystal must be connected between the XTI and XTO pins. This crystal must oscillate within the frequency ranges specified in the XTI switching specifications table on [page 23](#). Nothing other than the crystal and its load capacitors should be connected to XTI and XTO.

If an external crystal is connected to the XTI/XTO pins following the release of $\overline{\text{RST}}$, the device will automatically use the crystal as its clock source regardless of the presence of an input clock signal on the SYS_CLK pin.

In this mode, the CS4525 will automatically drive the generated internal clock out of the SYS_CLK pin. This can be disabled with the EnSysClk bit which will cause the SYS_CLK pin to become high-impedance. Also, the DivSysClk bit allows the frequency of the generated internal clock to be divided by 2 prior to being driven out of the SYS_CLK.

It should be noted that the internal oscillator driver is disabled when the CS4525 is in reset (RST is low). Any external devices connected to the SYS_CLK output will not receive a clock signal until the CS4525 is taken out of reset.

[Figure 13](#) below demonstrates a typical clocking configuration using the crystal oscillator.

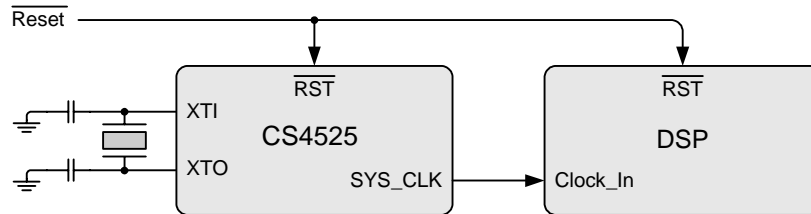

Figure 13. Typical Crystal Oscillator Clocking Configuration

Referenced Control	Register Location
EnSysClk.....	"SYS_CLK Output Enable (EnSysClk)" on page 64
DivSysClk.....	"SYS_CLK Output Divider (DivSysClk)" on page 64

6.1.2 Power-Up and Power-Down

The CS4525 will remain in a completely powered-down state with the control port inaccessible until the $\overline{\text{RST}}$ pin is brought high. Once $\overline{\text{RST}}$ is high, the control port will be accessible, but all other internal blocks will remain powered-down until they are powered-up via the control port or until hardware mode is entered.

When an external crystal is present on the XTI/XTO pins, software mode will be automatically entered 10 ms after the release of $\overline{\text{RST}}$. If SYS_CLK is used as an input, software mode is entered by writing to the control port within 10 ms after the release of $\overline{\text{RST}}$. If the control port is not written within this time, the device will begin to operate in hardware mode.

6.1.2.1 Recommended Power-Up Sequence

1. Hold $\overline{\text{RST}}$ low until the power supplies and the input SYS_CLK (if used) are stable.
2. Bring $\overline{\text{RST}}$ high.
The device will remain in a low-power state and the control port will be accessible. The device will automatically enter software mode after 10 ms if an external crystal is present on the XTI/XTO pins, at which time the output SYS_CLK signal will become active.
3. If SYS_CLK is used as an input, initiate a control port write to set the PDnAll bit in register 5Fh within 10 ms following the release of $\overline{\text{RST}}$.
This operation causes the device to enter software mode and places it in power-down mode.
4. If the LVD pin is tied low and VD is connected to 2.5 V, clear the SelectVD bit in the Power Ctrl register to indicate the 2.5 V VD supply level.
5. The desired register settings can be loaded while keeping the PDnAll bit set.
6. Clear the PDnAll bit to initiate the power-up sequence.

6.1.2.2 Recommended Power-Down Sequence

1. Set the PDnAll bit to power-down the device while eliminating audible pops.
2. Bring $\overline{\text{RST}}$ low to bring the device's power consumption to an absolute minimum.
3. Remove power.

Referenced Control	Register Location
PDnAll	"Power Down (PDnAll)" on page 81
LVD	"Select VD Level (SelectVD)" on page 81

6.1.3 Input Source Selection

The CS4525 can accept analog or digital audio input signals. Digital audio input signals are supplied through the serial audio input port as outlined in "Serial Audio Interfaces" on page 57. Analog audio input signals are supplied through the internal ADC as outlined in "Analog Inputs" on page 56. The input source is selected by the ADC/SP bit in the Input Config register.

In software mode, the serial audio input port supports I²S, Left-Justified and Right-Justified data formats. The serial audio input port digital interface format is configured by the DIF[2:0] bits in the Input Config register.

The CS4525 internal ADC includes a dedicated high-pass filter to remove any DC content from the ADC output signal prior to the internal ADC/serial audio input port input multiplexor. This high-pass filter can be bypassed by clearing the EnAnHPF bit.

Referenced Control	Register Location
ADC/SP	"Input Source Selection (ADC/SP)" on page 66
DIF[2:0]	"Input Serial Port Digital Interface Format (DIF [2:0])" on page 66
EnAnHPF	"ADC High-Pass Filter Enable (EnAnHPF)" on page 66

6.1.4 Digital Sound Processing

The CS4525 implements flexible digital sound processing operations including bass management cross-over, 2-way speaker crossovers, high- and low-pass shelving filters, programmable parametric EQ filters, adaptive loudness compensation, channel mixers, and volume controls.

The digital signal flow is shown in Figure 14 below. The signal processing blocks are described in detail in the following sections.

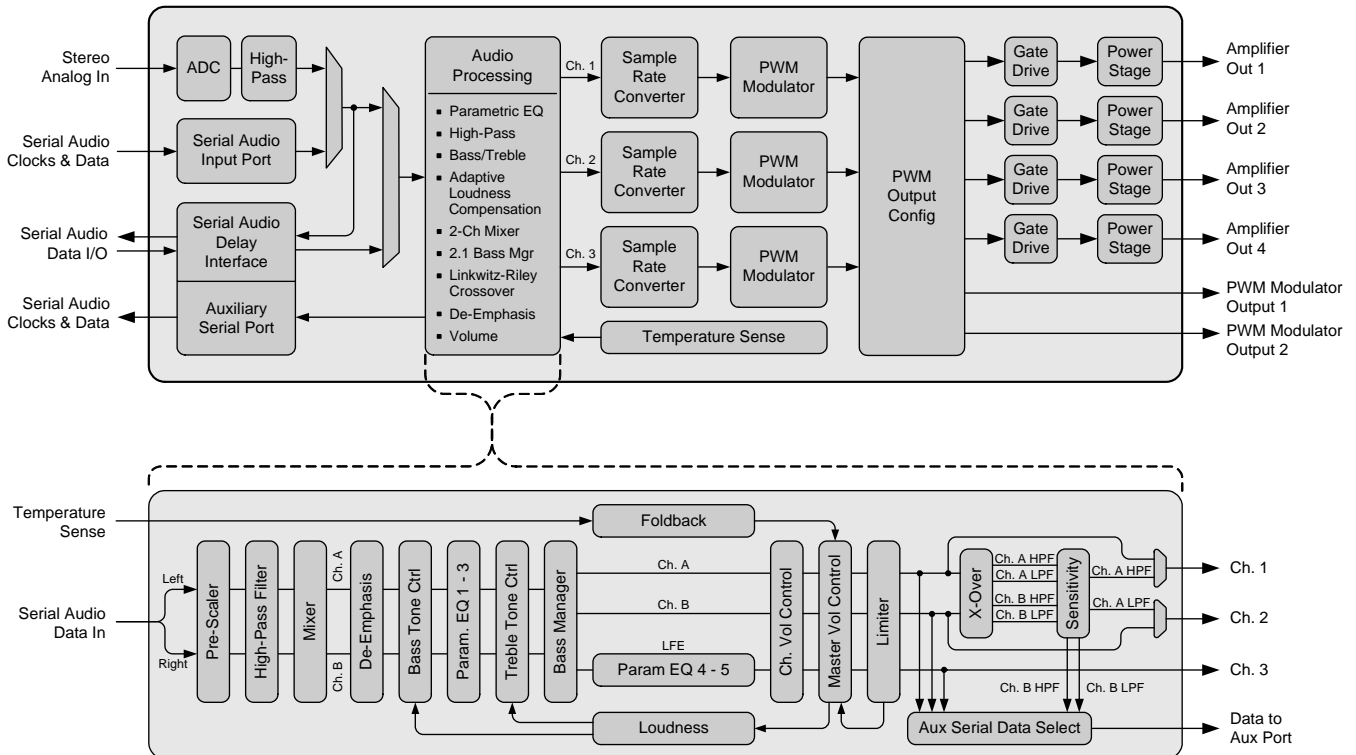

Figure 14. Digital Signal Flow

6.1.4.1 Pre-Scaler

Applying any gain to a full-scale signal in the digital domain will cause the signal to clip. To prevent this, a pre-scaler block is included prior to the internal digital signal processing blocks. This allows the input signal to be attenuated before processing to ensure that any signal boosting, such as gain in a shelving filter, will not cause a channel to clip.

The pre-scaler block allows up to -14.0 dB of attenuation in 2.0 dB increments and is controlled with the PreScale[2:0] bits.

Referenced Control	Register Location
PreScale[2:0].....	"Pre-Scale Attenuation (PreScale[2:0])" on page 70

6.1.4.2 Digital Signal Processing High-Pass Filter

The CS4525 includes a high-pass filter at the beginning of the digital signal processing chain to remove any DC content from the input signal prior to the remaining internal digital signal processing blocks. The high-pass filter operates by continuously subtracting a measure of the DC offset from the input signal and may be used regardless of the input data source.

The digital signal processing high-pass filter can be disabled by clearing the EnDigHPF bit.

Referenced Control	Register Location
EnDigHPF	"Digital Signal Processing High-Pass Filter (EnDigHPF)" on page 71

6.1.4.3 Channel Mixer

The CS4525 implements independent channel mixers to provide for both mono mixes and channel swaps for the left and right channels. The channel mixers are controlled by the LChMix[1:0] and RChMix[1:0] bits in the Mixer Config register.

To allow stereo headphone operation when a mono mix is configured, when the HP_DETECT/MUTE pin is configured for headphone detection (the HP/Mute bit is set), the operation of the left channel mixer is affected by the active state of the headphone detection input signal. In this configuration, when the left channel mixer is configured for a mono mix (LChMix[1:0] = 01 or 10) and the headphone detection input signal becomes active, the left channel mixer will be automatically reconfigured to output the left channel, thereby disabling the mono mix. When the headphone detection input signal becomes inactive, the mixer will be automatically reconfigured to operate as dictated by the LChMix[1:0] bits.

It should be noted that the right channel mixer output is unaffected by the headphone detection input signal and will always operate as dictated by the RChMix[1:0] bits.

Referenced Control	Register Location
LChMix[1:0]	"Left Channel Mixer (LChMix[1:0])" on page 71
RChMix[1:0]	"Right Channel Mixer (RChMix[1:0])" on page 70
HP/Mute	"HP_Detect/Mute Pin Mode (HP/Mute)" on page 65

6.1.4.4 De-Emphasis

The CS4525 includes an on-chip digital de-emphasis filter optimized for a sample rate of 44.1 kHz to accommodate audio recordings that utilize 50/15 μ s pre-emphasis equalization as a means of noise reduction. The filter response is shown in Figure 15. The de-emphasis filter is enabled and disabled by the DeEmph bit in the Tone Config register.

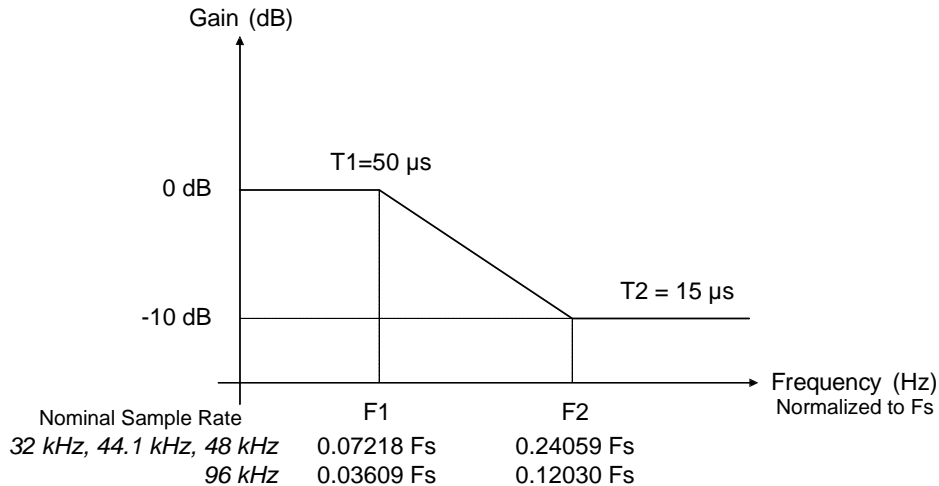

Figure 15. De-Emphasis Filter

Referenced Control	Register Location
DeEmph	"De-Emphasis Control (DeEmph)" on page 71

6.1.4.5 Tone Control

The CS4525 implements configurable bass and treble shelving filters to easily accommodate system tone control requirements. Each shelving filter has 4 selectable corner frequencies, and provides a cut/boost range from -10.5 dB to +12.0 dB in 1.5 dB increments. The tone control is enabled by the EnToneCtrl bit in the Tone Config register.

Each tone control is implemented with one of two preset internal filter sets. One set is optimized for a 32 kHz sample rate, and the other is optimized for 44.1 kHz, 48 kHz, and 96 kHz sample rates. The CS4525 automatically detects the input sample rate and chooses the appropriate filter set to apply. The available corner frequencies are shown in tables 2 and 3 below and are configured with the BassFc[1:0] and TrebFc[1:0] bits in the Tone Config register.

Note that the corner frequency of each filter set scales linearly with the input sample rate.

When the internal ADC is used as the serial audio data source, the input sample rate is nominally 48 kHz and the corresponding shelving frequency corners are available.

Input Sample Rate	Bass Fc 0	Bass Fc 1	Bass Fc 2	Bass Fc 3
32 kHz	50 Hz	100 Hz	200 Hz	250 Hz
44.1 kHz	48 Hz	96 Hz	192 Hz	240 Hz
48 kHz, 96 kHz	52 Hz	104 Hz	208 Hz	260 Hz

Table 2. Bass Shelving Filter Corner Frequencies

Input Sample Rate	Treble Fc 0	Treble Fc 1	Treble Fc 2	Treble Fc 3
32 kHz	5.0 kHz	7.0 kHz	10.0 kHz	15.0 kHz
44.1 kHz	4.8 kHz	6.7 kHz	9.6 kHz	14.4 kHz
48 kHz, 96 kHz	5.2 kHz	7.3 kHz	10.4 kHz	15.6 kHz

Table 3. Treble Shelving Filter Corner Frequencies

The cut/boost level of the bass and treble shelving filters are set by the Bass[3:0] and Treble[3:0] bits in the Tone Control register.

Referenced Control	Register Location
EnToneCtrl	"Tone Control Enable (EnToneCtrl)" on page 72
TrebFc[1:0]	"Treble Corner Frequency (TrebFc[1:0])" on page 72
BassFc[1:0]	"Bass Corner Frequency (BassFc[1:0])" on page 72
Treble[3:0]	"Treble Gain Level (Treb[3:0])" on page 72
Bass[3:0]	"Bass Gain Level (Bass[3:0])" on page 73

6.1.4.6 Parametric EQ

The CS4525 implements 5 fully programmable parametric EQ filters. Three of the filters are 2-channel filters dedicated to the channel A/B pair, and the remaining two are single-channel filters dedicated to the LFE channel generated by the bass manager.

The filters are implemented in the bi-quad form shown below.

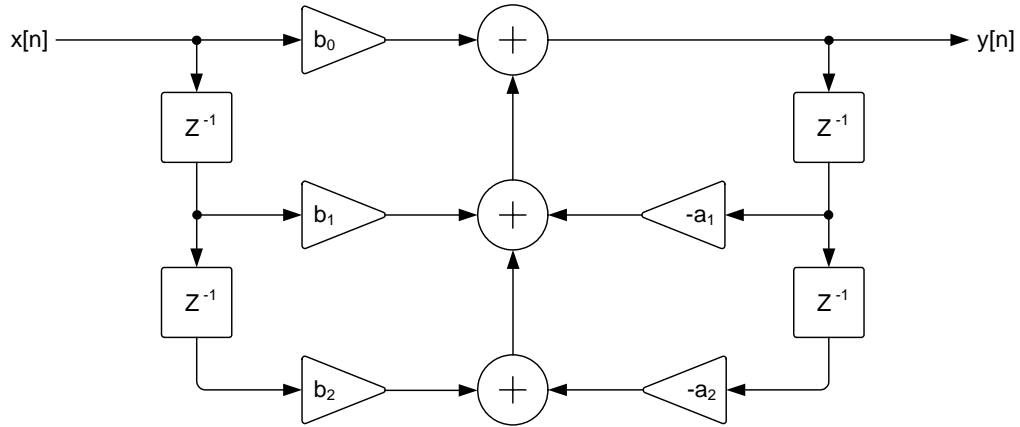

Figure 16. Bi-Quad Filter Architecture

This architecture is represented by the equation shown below where $y[n]$ represents the output sample value and $x[n]$ represents the input sample value.

$$y[n] = b_0x[n] + b_1x[n-1] + b_2x[n-2] - a_1x[n-1] - a_2x[n-2]$$

Equation 1. Bi-Quad Filter Equation

The coefficients are represented in binary form by 24-bit signed values stored in 3.21 two's complement format. The 3 MSB's represent the sign bit and the whole-number portion of the decimal coefficient, and the 21 LSB's represent the fractional portion of the decimal coefficient. The coefficient values must be in the range of -3.99996 decimal (80 00 00 hex) to 3.99996 decimal (7F FF FF hex).

The binary coefficient values are stored in registers 0Ah - 54h. Each 24-bit coefficient is split into 3 bytes, each of which is mapped to an individually accessible register location. See the ["Register Quick Reference" section beginning on page 61](#) for the specific register locations for each coefficient.

By default, all b_0 coefficients are set to 1 decimal, and all other coefficients are set to 0 decimal. This implements a pass-through function.

Parametric equalizers 1, 2, and 3 can be independently enabled and disabled for channel A and B with the EnChAPEq and EnChBPEq bits located in the EQ Config register. The EnLFEPEq bit in the same register enables and disables parametric equalizers 4 and 5 for the LFE channel.

Referenced Control	Register Location
EnChAPEq.....	"Enable Channel A Parametric EQ (EnChAPEq)" on page 74
EnChBPEq.....	"Enable Channel B Parametric EQ (EnChBPEq)" on page 74
EnLFEPEq.....	"Enable LFE Parametric EQ (EnLFEPEq)" on page 74

6.1.4.7 Adaptive Loudness Compensation

The CS4525 includes adaptive loudness compensation to enhance the audibility of program material at low volume levels. The adaptive loudness compensation feature operates by varying the bass and treble boost of the tone control shelving filters as the volume level changes.

The level of boost added to the shelving filters is determined by the average of the effective volume settings of channels A and B after the master volume control. As this average volume setting decreases from 0 dB, the boost of the bass and treble shelving filters is gradually increased until it reaches the maximum boost level of 12.0 dB. As the volume is increased, the boost applied due to the adaptive loudness compensation feature will be gradually removed until it reaches the level specified by the Treble[3:0] and Bass[3:0] bits in the Tone Control register.

The adaptive loudness compensation feature is enabled by setting the Loudness bit in the Tone Config register. When the loudness feature is enabled, it immediately evaluates the effective average volume and applies bass and treble boost accordingly. When disabled, any treble or bass boost applied due to the loudness feature will be removed.

Because the adaptive loudness compensation filter operates by adjusting the boost level of the tone control shelving filters, it is necessary that they be enabled with the EnToneCtrl bit in the Tone Config register in order for the loudness feature to be operational. If the tone control filters are disabled, the adaptive loudness compensation feature will not be functional.

Referenced Control	Register Location
Loudness.....	"Adaptive Loudness Compensation Control (Loudness)" on page 71
EnToneCtrl	"Tone Control Enable (EnToneCtrl)" on page 72
TrebFc[1:0]	"Treble Corner Frequency (TrebFc[1:0])" on page 72
BassFc[1:0]	"Bass Corner Frequency (BassFc[1:0])" on page 72
Treble[3:0]	"Treble Gain Level (Treb[3:0])" on page 72
Bass[3:0]	"Bass Gain Level (Bass[3:0])" on page 73

6.1.4.8 Bass Management

The CS4525 implements a dedicated stereo 24 dB/octave Linkwitz-Riley crossover with adjustable cross-over frequency to achieve bass management for 2.1 configurations. The filter's stereo high-pass outputs are used to drive the full-range speakers, and its stereo low-pass outputs are each attenuated by 6 dB and summed to drive the LFE channel.

The bass management crossover is implemented with one of two preset internal filter sets. One set is optimized for a 32 kHz sample rate, and the other is optimized for 44.1 kHz, 48 kHz, and 96 kHz sample rates. The CS4525 automatically detects the input sample rate and chooses the appropriate filter set to apply. The available bass management cross-over frequencies are shown in [Table 4](#) below and are configured with the BassMgr[2:0] bits in the EQ Config register.

Note that the corner frequency of each filter set scales linearly with the input sample rate.

When the internal ADC is used as the serial audio data source, the input sample rate is nominally 48 kHz and the corresponding shelving frequency corners are available.

	Input Sample Rate		
	32 kHz	44.1 kHz	48 kHz, 96 kHz
Bass Manager Freq 1	80 Hz	77 Hz	83 Hz
Bass Manager Freq 2	120 Hz	115 Hz	125 Hz
Bass Manager Freq 3	160 Hz	153 Hz	167 Hz
Bass Manager Freq 4	200 Hz	192 Hz	209 Hz
Bass Manager Freq 5	240 Hz	230 Hz	250 Hz
Bass Manager Freq 6	280 Hz	268 Hz	292 Hz
Bass Manager Freq 7	320 Hz	307 Hz	334 Hz

Table 4. Bass Management Cross-Over Frequencies

The BassMgr[2:0] bits also allow the bass manager to be disabled. When disabled, the bass management crossover is bypassed and no signal is presented on the LFE channel.

To allow full-range headphone operation, when the HP_DETECT/MUTE pin is configured for headphone detection (the HP/Mute bit is set), the operation of the bass manager is affected by the active state of the headphone detection input signal. In this configuration, when the bass manager is enabled, (BassMgr[2:0] bits not equal to '000') and the headphone detection input signal becomes active, the bass manager will be automatically disabled. When the headphone detection input signal becomes inactive, the bass manager will be automatically reconfigured to operate as dictated by the BassMgr[2:0] bits.

Referenced Control	Register Location
BassMgr[2:0]	"Bass Cross-Over Frequency (BassMgr[2:0])" on page 73
HP/Mute	"HP_Detect/Mute Pin Mode (HP/Mute)" on page 65

6.1.4.9 Volume and Muting Control

The CS4525's volume control architecture provides the ability to control the level of each output channel on both an individual and master basis.

Individual control allows the volume and mute state of a single channel to be changed independently from the other channels within the device. The CS4525 provides 3 individual volume and muting controls, each permanently assigned to one channel within the device.

Each channel has a corresponding Ch X Vol register used to gain or attenuate the channel from +24 dB to -103 dB in 0.5 dB steps. Each output can be independently muted via the MuteChX bits in the Mute Control register.

Master control allows the volume of all channels to be changed simultaneously by offsetting each channel's individual volume setting by +24 dB to -103 dB in 0.5 dB steps. Master volume control is accomplished via the Master Vol register.

The PWM outputs can be configured to output silence as a modulated signal or an exact 50% duty cycle signal during a mute condition. This selection is achieved via the Mute50/50 bit in the Volume Cfg register.

The AutoMute bit in the same register dictates whether the device will automatically mute after the reception of 8192 consecutive samples of static 0 or -1. When the AutoMute function is enabled, a single sample of non-static data will cause the automatic mute to be released.

The CS4525 implements soft-ramp and zero-crossing detection capabilities to provide noise-free level transitions. When the zero-crossing function is enabled, all volume and muting changes are made on an output signal zero-crossing. The zero-crossing detection function is implemented independently for each channel. When the soft-ramp function is enabled, the volume is ramped from its initial to its final level at a rate of ½ dB every 4 samples for 32, 44.1, and 48 kHz sample rates, and ½ dB every 8 samples for a 96 kHz sampling rate.

All volume and muting changes are implemented as dictated by the soft-ramp and zero-cross settings configured by the SZCMode[1:0] bits in the Volume Cfg register.

Referenced Control	Register Location
Ch X Vol	"Channel 1, 2, & 3 Volume Control (Address 58h, 59h, & 5Ah)" on page 78
Master Vol	"Master Volume Control (Address 57h)" on page 77
Mute50/50	"Enable 50% Duty Cycle for Mute Condition (Mute50/50)" on page 75
AutoMute	"Auto-Mute (AutoMute)" on page 75
SZCMode	"Soft Ramp and Zero Cross Control (SZCMode[1:0])" on page 75

6.1.4.10 Peak Signal Limiter

When enabled, the limiter monitors the digital output following the volume control block, detects when peak levels exceed a selectable maximum threshold level and lowers the volume at a programmable attack rate until the signal peaks fall below the maximum threshold. When the signal level falls below a selectable minimum threshold, the volume returns to its original level (as determined by the individual and master volume control registers) at a programmable release rate. Attack and release rates are affected by the soft ramp/zero cross settings and sample rate, F_s .

Recommended settings: Best limiting performance may be realized with the fastest attack and slowest release setting with soft ramp enabled in the control registers. Use the “minimum” bits to set a threshold slightly below the maximum threshold to cushion the sound as the limiter attacks and releases.

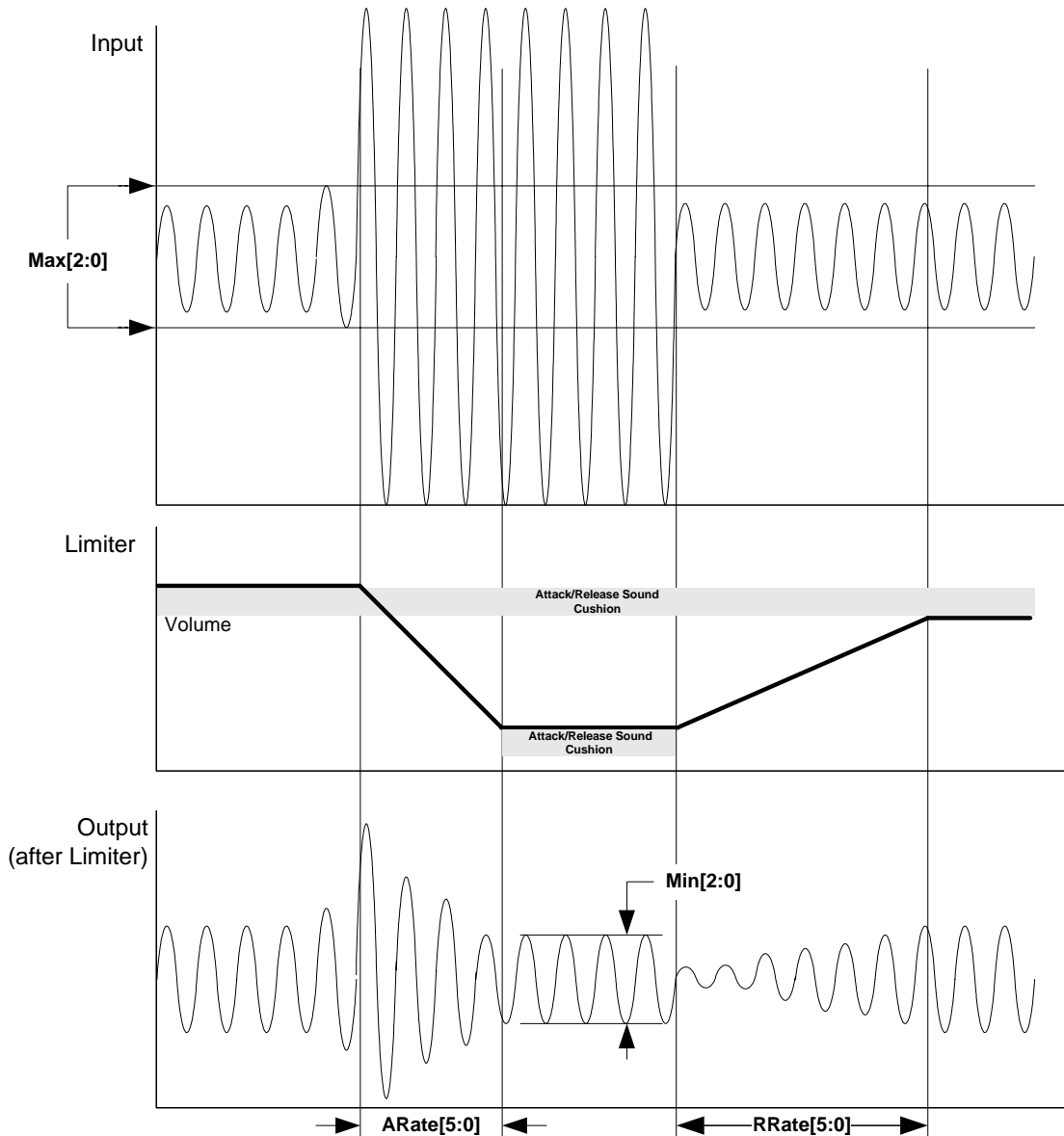

Figure 17. Peak Signal Detection & Limiting

By default, the limiter affects all channels when the maximum threshold is exceeded on any single channel. This default functionality is designed to keep all output channels at the same volume level while the limiter is in use. This behavior can be disabled by clearing the LimitAll bit in the Limiter Cfg 1 register.

When the LimitAll feature is activated, attenuation will be applied to all channels when a single channel exceeds the maximum threshold and released when the level of all channels is below the minimum threshold. When the LimitAll feature is de-activated, limiter attenuation will be applied and released on a per-channel basis and will only affect the channel on which the limiter event occurred.

The limiter can be enabled by setting the EnLimiter bit in the Limiter Cfg register.

Referenced Control	Register Location
EnLimiter	"Peak Detect and Limiter Enable (EnLimiter)" on page 80
LimitAll	"Peak Signal Limit All Channels (LimitAll)" on page 79
Max[2:0]	"Maximum Threshold (Max[2:0])" on page 79
Min[2:0]	"Minimum Threshold (Min[2:0])" on page 79
ARate[5:0]	"Limiter Attack Rate (ARate[5:0])" on page 80
RRate[5:0]	"Limiter Release Rate (RRate[5:0])" on page 80

6.1.4.11 Thermal Foldback

The CS4525 implements comprehensive thermal foldback features to guard against damaging thermal overload conditions.

The thermal foldback algorithm begins limiting the volume of the digital audio input to the amplifier stage as the junction temperatures rise above the maximum safe operating range specified by the thermal warning trip point listed in the [PWM Power Output Characteristics](#) table on [page 20](#). This effectively limits the output power capability of the device, thereby allowing the temperature to reduce to acceptable levels without fully interrupting operation. As the device cools, the applied attenuation is gradually released until a new thermal equilibrium is reached or all applied attenuation has been released thereby allowing the device to again achieve its full output power capability.

Attenuation applied due to thermal foldback reduces the audio output level in a linear manner. [Figure 18](#) below demonstrates the foldback process.

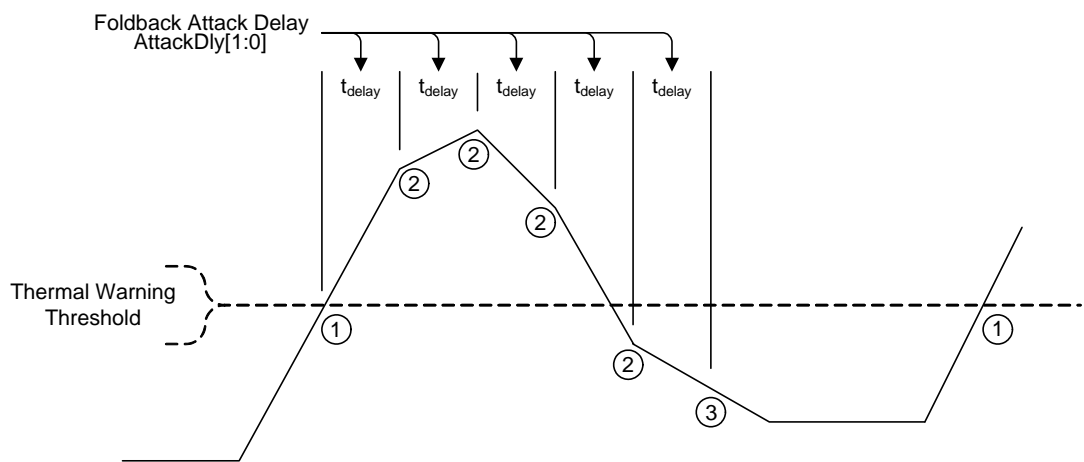

- ① When the junction temperature crosses the thermal warning threshold, the foldback attack delay timer is started.
- ② When the foldback attack delay timer reaches t_{delay} seconds, the junction temperature is checked. If the junction temperature is above the thermal warning threshold, the output volume level is lowered by 0.5 dB and the foldback attack timer is restarted.

The junction temperature is checked after each foldback attack timer timeout, and if necessary, the output volume level is lowered accordingly.

If the junction temperature is found to be below the thermal warning threshold, the foldback attack timer is restarted once again, but the output volume level is not altered. The foldback algorithm then proceeds to step 3.

- ③ The junction temperature is checked once again after the next foldback attack timer timeout. If it has remained below the thermal warning threshold since the last check, the device will begin to release any attenuation applied as a result of the foldback event. Setting the LockAdj bit will prevent the device from removing the applied attenuation when the thermal overload condition has cleared.

If the junction temperature crosses the thermal warning threshold again, the foldback algorithm will once again enter step 1.

Figure 18. Foldback Process

The AttackDly[1:0] bits in the Foldback Cfg register allow the foldback attack delay timeout period to be adjusted from approximately 0.5 seconds to approximately 2.0 seconds. The maximum attenuation applied by the thermal foldback algorithm can be restricted to -30 dB by setting the EnFloor bit in the same register.

The foldback adjustment lock feature causes the attenuation applied by the foldback algorithm to be maintained after the foldback condition has subsided. The applied attenuation will continue to be applied until the master volume or all active channel volume controls are lowered below the foldback attenuation level, or until a subsequent foldback condition occurs causing the applied attenuation to be lowered further. If the foldback algorithm applies attenuation while this feature is enabled, when the feature is subsequently disabled, the applied attenuation will be gradually released as long as the temperature remains within the safe operating range. This foldback lock adjustment feature is enabled by the LockAdj bit in the Foldback Cfg register.

Thermal warnings will only affect the foldback algorithm and cause attenuation to be applied when enabled by the EnTherm bit in the Foldback Cfg register.

The CS4525 can be configured to accept an external thermal warning indicator input. When in this configuration, an active input signal indicates that a thermal warning threshold has been exceeded. If thermal foldback is enabled, the foldback algorithm will respond as described above making no distinction between an internal or external thermal warning condition. See [“External Warning Input Port” on page 43](#) for more information.

Referenced Control	Register Location
EnTherm	“Enable Thermal Foldback (EnTherm)” on page 69
AttackDly[1:0]	“Foldback Attack Delay (AttackDly[1:0])” on page 69
EnFloor	“Enable Foldback Floor (EnFloor)” on page 70
LockAdj	“Lock Foldback Adjust (LockAdj)” on page 69

6.1.4.12 2-Way Crossover & Sensitivity Control

The CS4525 implements a dedicated stereo 24 dB/octave Linkwitz-Riley crossover filter with adjustable cross-over frequency and sensitivity control to facilitate 2-way speaker configurations. The filter's high-pass output can be used to drive the tweeter, and its low-pass output is used can be drive the mid-range/woofer. The sensitivity control is included to adjust the level of the high-pass and low-pass outputs to compensate for differences in the tweeter and mid-range/woofer sensitivity.

The two-way crossover is implemented with one of two preset internal filter sets. One set is optimized for a 32 kHz sample rate, and the other is optimized for 44.1 kHz, 48 kHz, and 96 kHz sample rates. The CS4525 automatically detects the input sample rate and chooses the appropriate filter set to apply. The available cross-over frequencies are shown in Table 5 below and are configured with the 2WayFreq[2:0] bits in the Volume Cfg register.

Note that the corner frequency of each filter set scales linearly with the input sample rate.

When the internal ADC is used as the serial audio data source, the input sample rate is nominally 48 kHz and the corresponding shelving frequency corners are available.

	Input Sample Rate		
	32 kHz	44.1 kHz	48 kHz, 96 kHz
X-Over Freq 0	2.0 kHz	1.92 kHz	2.09 kHz
X-Over Freq 1	2.2 kHz	2.11 kHz	2.30 kHz
X-Over Freq 2	2.4 kHz	2.30 kHz	2.50 kHz
X-Over Freq 3	2.6 kHz	2.49 kHz	2.71 kHz
X-Over Freq 4	2.8 kHz	2.68 kHz	2.92 kHz
X-Over Freq 5	3.0 kHz	2.88 kHz	3.13 kHz
X-Over Freq 6	3.2 kHz	3.07 kHz	3.34 kHz
X-Over Freq 7	3.4 kHz	3.26 kHz	3.55 kHz

Table 5. 2-Way Cross-Over Frequencies

The sensitivity level of the high- and low-pass outputs of the crossovers can be independently adjusted from 0 dB to -7.5 dB in 0.5 dB increments. The maximum attenuation level of -7.5 dB will compensate for an approximate 4 dB difference in sound pressure level (SPL) between the tweeter and the mid-range/woofer drivers. The sensitivity is adjusted using the HighPass[3:0] and LowPass[3:0] bits in the Sensitivity register. Note that these bits affect the sensitivity of both channel 1 and channel 2 low- and high-pass outputs.

The 2-way crossover can be enabled by setting the En2Way bit in the Volume Cfg register.

Referenced Control	Register Location
En2Way.....	"Enable 2-Way Crossover (En2Way)" on page 76
2WayFreq[2:0].....	"2-Way Cross-Over Frequency (2WayFreq[2:0])" on page 76
HighPass[3:0].....	"Channel 1 and Channel 2 High-Pass Sensitivity Adjust (HighPass[3:0])" on page 77
LowPass[3:0].....	"Channel 1 and Channel 2 Low-Pass Sensitivity Adjust (LowPass[3:0])" on page 76

6.1.5 Auxiliary Serial Output

The CS4525 includes a stereo auxiliary serial output which allows an external device to leverage on its internal signal processing and routing capabilities. The auxiliary serial output can receive its data from any of the sources shown in the [Digital Signal Flow](#) diagram on [page 29](#).

The supported output data routing configurations are shown in [Table 6](#) below. By default, the serial port is configured to output channels 1 and 2 on the auxiliary output data channels 1 and 2 respectively.

LChDSEL[1:0]	Aux Left Channel Data	RChDSEL[1:0]	Aux Right Channel Data
00	Channel A	00	Channel A
01	Channel B	01	Channel B
10	LFE Channel	10	LFE Channel
11	Channel B X-Over HPF	11	Channel B X-Over LPF

Table 6. Auxiliary Serial Port Data Output

The data output on each channel is set by the LChDSEL[1:0] and RChDSEL[1:0] bits in the Aux Port Configuration register. The auxiliary port can be enabled using the EnAuxPort bit in the same register. When enabled, the port operates as a master and clocks out data in the format dictated by the AuxI²S/LJ bits. When disabled, the AUX_LRCK, AUX_SCLK, and AUX_SDOOUT pins continuously drive a logic '0'.

Referenced Control	Register Location
EnAuxPort	"Enable Aux Serial Port (EnAuxPort)" on page 67
LChDSEL[1:0]	"Aux Serial Port Left Channel Data Select (LChDSEL[1:0])" on page 68
RChDSEL[1:0]	"Aux Serial Port Right Channel Data Select (RChDSEL[1:0])" on page 67
AuxI ² S/LJ	"Aux/Delay Serial Port Digital Interface Format (AuxI ² S/LJ)" on page 67

6.1.6 Serial Audio Delay & Warning Input Port

The CS4525 includes a configurable delay and warning port to allow easy system integration of external lip-sync delay devices or warning inputs from external amplifiers. The port can be configured as a serial audio delay interface, an external warning input port, or disabled by the DlyPortCfg[1:0] bits in the Aux Config register. When disabled, the DLY_SDOOUT and DLY_SDIN/EX_TWR pins become high-impedance.

Referenced Control	Register Location
DlyPortCfg	"Delay & Warning Port Configuration (DlyPortCfg[1:0])" on page 67

6.1.6.1 Serial Audio Delay Interface

Video processing and reproduction circuitry in digital video display devices can often introduce noticeably more delay than is introduced by the device's audio processing and reproduction circuitry. This can result in a phenomenon known as lip-synch delay - a delay present between the video and audio content being reproduced.

To help overcome this problem, the CS4525 delay and warning port can be configured as serial audio delay interface. This interface consists of a serial audio input/output port to facilitate the use of an external serial audio delay device. The port routes the serial data from the selected input source (the ADC or the serial input port) out to an external serial audio delay device, and then back in to the CS4525 internal digital sound processing blocks. The delay serial audio interface signals include DLY_SDOOUT and DLY_SDIN/EX_TWR and are clocked from AUX_LRCK and AUX_SCLK. The serial data is output on the DLY_SDOOUT pin and input on the DLY_SDIN/EX_TWR in the format specified by the AuxI²S/LJ bits in

the Aux Config register. Because the delay interface uses the auxiliary port clock signals, the auxiliary serial port must be enabled using the EnAuxPort bit in the Aux Port Configuration register to allow the delay interface to operate properly.

Referenced Control	Register Location
AuxI ² S/LJ.....	"Aux/Delay Serial Port Digital Interface Format (AuxI ² S/LJ)" on page 67
EnAuxPort.....	"Enable Aux Serial Port (EnAuxPort)" on page 67

6.1.6.2 External Warning Input Port

When implementing external PWM power stage devices with thermal warning indicator outputs, it can be useful to provide these warning signals as an input to the internal thermal foldback algorithm. This allows the CS4525 to automatically respond to the external devices' thermal warning conditions without completely disrupting the system's operation.

When configured as an external warning input port, the $\overline{\text{DLY_SDIN/EX_TWR}}$ is an active-low thermal warning input to the foldback algorithm and the DLY_SDOOUT pin becomes high-impedance.

In order for the foldback algorithm to act on the external thermal warning input signal, the thermal foldback algorithm must be enabled by the EnTherm bit in the Foldback Cfg register. See "Thermal Foldback" on page 39 for more information.

Referenced Control	Register Location
EnTherm.....	"Enable Thermal Foldback (EnTherm)" on page 69

6.1.7 PWM Output Configuration

The CS4525 supports flexible PWM output configurations to enable a wide variety of system implementations. The 3 internal modulators can be used to generate multiple power output configurations and a number of independently selected logic-level PWM output channel combinations. PWM PopGuard is available for pop-free power up in half-bridge configurations, and PWM signal delays may be inserted to manage system switching noise.

6.1.7.1 PWM Power Output Configurations

Three PWM power output configurations are supported as shown in Table 7 below. The configurations support stereo full-bridge, stereo half-bridge with full-bridge LFE, and mono parallel full-bridge output.

OutputCfg[1:0]	Power Configuration	Output Signal	Output Pin(s)
00	2 Ch. Full-Bridge	Channel 1 + Channel 1 - Channel 2 + Channel 2 -	OUT1 OUT2 OUT3 OUT4
01	2 Ch. Half-Bridge + 1 Ch. Full-Bridge	Channel 1 + Channel 2 + Channel 3 + Channel 3 -	OUT1 OUT2 OUT3 OUT4
10	1 Ch. Parallel Full-Bridge	Channel 1 + Channel 1 -	OUT1, OUT2 OUT3, OUT4

Table 7. PWM Power Output Configurations

The configurations are selected by the OutputCfg[1:0] bits in the Output Cfg register and must only be changed when the device is in power-down mode (the PDnAll bit is set). Any attempt to write the OutputCfg[1:0] bits while the device is powered-up will be ignored.

It should be noted that signal on channels 1, 2, and 3 is dependent upon the digital sound processing blocks being used. For instance, if the 2-way crossover is enabled, channel 1 and 2 contain the 2-way crossover channel A high- and low-pass outputs respectively. For more information, see the [Digital Sound Processing](#) section and [Figure 14 on page 29](#).

Referenced Control	Register Location
OutputCfg[1:0].....	"Output Configuration (OutputCfg[1:0])" on page 68
PDnAll	"Power Down (PDnAll)" on page 81

6.1.7.2 PWM_SIG Logic-Level Output Configurations

Four channel mapping output configurations are supported for the PWM_SIG output pins as shown in [Table 8](#) below. The configurations support stereo, channel 1 with LFE, and channel 2 with LFE. When disabled, the PWM_SIG pins continuously drive a logic '0'. The configurations are selected by the PWMDSel[1:0] bits in the Output Cfg register

PWMDSel[1:0]	PWM_SIG1	PWM_SIG2
00	Output disabled.	Output disabled.
01	Channel 1	Channel 2
10	Channel 1	Channel 3
11	Channel 2	Channel 3

Table 8. PWM Logic-Level Output Configurations

To allow stereo headphone operation when the PWM logic-level outputs are mapped in a non-stereo output configuration, if the HP_DETECT/MUTE pin is configured for headphone detection (the HP/Mute bit is set), the PWM logic-level output mapping is affected by the active state of the headphone detection input signal. In this configuration, the PWM_SIG1 and PWM_SIG2 output pins will output audio from channel 1 and channel 2 respectively regardless of the setting of the PWMDSel[1:0] bits when the headphone detection input is active. When the headphone detection input signal becomes inactive, the PWM logic-level outputs will be automatically reconfigured to the channel mapping dictated by the PWMDSel[1:0] bits. See the [Headphone Detection & Hardware Mute Input](#) section on [page 47](#) for more information.

It should be noted that signal on channels 1, 2, and 3 is dependent upon the digital sound processing blocks being used. For instance, if the 2-way crossover is enabled, channel 1 and 2 contain the 2-way crossover channel A high- and low-pass outputs respectively. For more information, see the [Digital Sound Processing](#) section and [Figure 14 on page 29](#).

Referenced Control	Register Location
PWMDSel[1:0].....	"PWM Signals Output Data Select (PWMDSel[1:0])" on page 68
HP/Mute	"HP_Detect/Mute Pin Mode (HP/Mute)" on page 65
PDnAll	"Power Down (PDnAll)" on page 81

6.1.7.3 PWM PopGuard Transient Control

The CS4525 uses PopGuard technology to minimize the effects of power-up and power-down output transients commonly produced by half-bridge, single supply amplifiers implemented with external DC-blocking capacitors connected in series with the audio outputs.

PWM PopGuard operates by linearly ramping the PWM power outputs up to and down from their bias point of $V_P/2$ when a channel is powered up and down respectively using the PDnOutX or PDnAll bits. This gradual voltage ramp minimizes output transients while the DC blocking capacitor is charged and discharged.

The PWM PopGuard output ramp time can be varied from approximately 0.70 seconds to approximately 0.85 seconds and can be completely disabled via the RmpSpeed[1:0] bits in the Foldback Cfg register. All output channels are affected by the RmpSpeed[1:0] bits, and PWM PopGuard is disabled by default.

Referenced Control	Register Location
RmpSpeed[1:0]	"Ramp Speed (RmpSpd[1:0])" on page 70
PDnAll	"Power Down (PDnAll)" on page 81
PDnOutX	"Power Down PWM Power Output X (PDnOutX)" on page 81

6.1.7.4 PWM Channel Delay

The CS4525 includes a PWM output signal delay mechanism. This mechanism allows the PWM switching edges to be offset between channels as a method of managing switching noise and reducing radiated emissions.

The OutputDly[3:0] bits in the Output Cfg register are used to adjust the channel delay amount from 0 to 15 SYS_CLK or crystal input clock cycles, whichever is used as the input clock source. The absolute delay time is calculated by multiplying the setting of the OutputDly[3:0] bits by the period of the input clock source. By default, no delay is inserted.

When the power outputs are configured for 2-channel full-bridge operation, the OUT3/OUT4 signal pair is delayed from the OUT1/OUT2 signal pair by the delay amount as shown in [Figure 19](#) below.

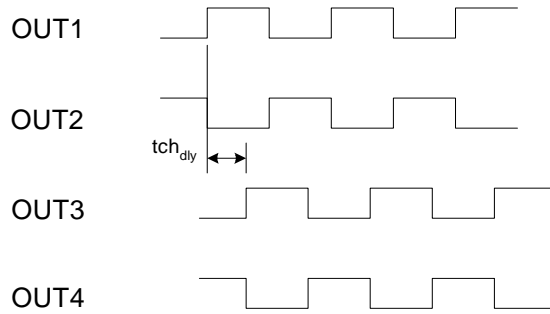

Figure 19. 2-Channel Full-Bridge PWM Output Delay

When the power outputs are configured for 3-channel (2-channel half-bridge and 1-channel full-bridge) operation, OUT2 is delayed from OUT1 by the delay amount, and the OUT3/OUT4 pair is delayed from OUT2 by the delay amount as shown in [Figure 20](#) below.

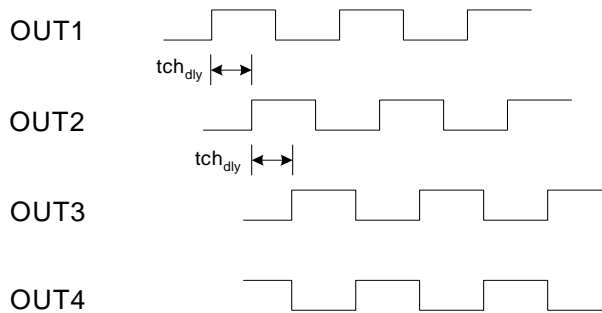

Figure 20. 3-Channel PWM Output Delay

The OutputDly[3:0] bits can only be changed when all modulators and associated logic are in the power-down state by setting the PDnAll bit. Attempts to write these bits while the PDnAll bit is cleared will be ignored.

Referenced Control	Register Location
OutputDly[3:0]	"Channel Delay Settings (OutputDly[3:0])" on page 68

6.1.7.5 PWM AM Frequency Shift

When using a PWM amplifier in a system containing an AM tuner, it is possible that the PWM switch rate conflicts with the desired tuning frequency of the AM tuner. To overcome this effect, the CS4525 includes PWM switch rate shift feature.

The feature adjusts the PWM switching frequency and quantization levels to remove interference when the desired tuning frequency of an AM tuner is positioned near the PWM switching rate. This feature is enabled by setting the FreqShift bit in the Clock Config register. When this feature is enabled, the output switch rate is lowered and the quantization levels are increased as shown in [Table 9](#) below.

Supplied XTAL or SYS_CLK Frequency	PWM Switch Rate	Quantization Levels
18.432 MHz	329.143 kHz	56
24.576 MHz	341.300 kHz	72
27.000 MHz	375 kHz	72

Table 9. PWM Output Switching Rates and Quantization Levels

The nominal PWM switching frequencies and quantization levels are discussed in [“PWM Modulators and Sample Rate Converters”](#) on page 53.

Referenced Control	Register Location
FreqShift.....	“AM Frequency Shifting (FreqShift)” on page 65

6.1.8 Headphone Detection & Hardware Mute Input

The CS4525 includes a configurable HP_DETECT/MUTE input pin which can be used as a hardware mute input or a headphone detection input. The function of this pin is set by the HP/Mute bit in the Clock Config register.

When configured as a mute input pin, all PWM modulators and the AUX_SDOOUT signal will be placed in a mute state when the pin is active.

When configured as a headphone detect input pin and the HP_DETECT/MUTE input is active, the PWM_SIG1 and PWM_SIG2 output pins will output audio from channel 1 and channel 2 respectively regardless of the setting of the PWMDSel[1:0] bits; see [“PWM_SIG Logic-Level Output Configurations”](#) on page 44 for more information. The OUT1 - OUT4 PWM driver outputs will mute by outputting a non-modulated 50% duty cycle signal. If the Ch1Mix[1:0] bits are configured for a mono mix on channel 1, the mix will be disabled and channel 1 will be output on PWM_SIG1 while the headphone detect input signal is active; see [“Channel Mixer”](#) on page 30 for more information. If the bass manager is enabled, it will be automatically disabled while the headphone detect input signal is active; see [“Bass Management”](#) on page 35 for more information.

When configured as a headphone detect input pin and the input is inactive, the OUT1 - OUT4 driver outputs will output audio according to the channel mixer and bass manager registers settings, and the PWM_SIG output pins will mute by outputting a non-modulated 50% duty cycle.

In both configurations, the active logic input level is determined by the HP/MutePol bit.

Referenced Control	Register Location
HP/Mute	“HP_Detect/Mute Pin Mode (HP/Mute)” on page 65
HP/MutePol	“HP_Detect/Mute Pin Active Logic Level (HP/MutePol)” on page 65
PWMDSel[1:0].....	“PWM Signals Output Data Select (PWMDSel[1:0])” on page 68

6.1.9 *Interrupt Reporting*

The CS4525 has comprehensive interrupt reporting capabilities. Many conditions including SRC lock, ADC overflow, digital data path overflow, and amplifier errors can cause an interrupt.

The $\overline{\text{INT}}$ output pin is intended to drive an interrupt input pin on a host microcontroller. The $\overline{\text{INT}}$ pin is an open-drain active-low output and requires an external pull-up for proper operation.

If an interrupt source is un-masked, its occurrence will cause the interrupt output pin to become active. To enhance flexibility, each interrupt source may be masked such that its occurrence does not cause the interrupt output pin to become active. This masking function is accomplished by clearing an interrupt's respective mask bit located in the 4 LSB's of the Interrupt register.

When a specific interrupt condition occurs, it's respective bit located in the 4 MSB's of the Interrupt register will be set to indicate that a change has occurred for the associated interrupt type. When the interrupt register is read, the contents of the 4 MSB's will be cleared. The Int Status register may then be read to determine the current state of the interrupt source.

For specific information regarding interrupt types and reporting, see the Interrupt, Int Status and Amp Error register descriptions.

Referenced Control	Register Location
Interrupt Register	"Interrupt Register (Address 60h)" on page 82
Int Status Register.....	"Interrupt Status Register (Address 61h) - Read Only" on page 84
Amp Error Register	"Amplifier Error Status (Address 62h) - Read Only" on page 85

6.1.10 *Automatic Power Stage Shut-Down*

To prevent permanent damage, the CS4525 will automatically shut down its internal PWM power output stages when a thermal error, PWM power output over-current error, or VP under-voltage condition occurs. In the shut-down state, all digital functions of the device will operate as normal, however the PWM power output pins become high-impedance.

The levels of the over-current error, thermal error, and VP under-voltage trip points are listed in the [PWM Power Output Characteristics](#) table on [page 20](#). Automatic shut-down will occur whenever any of these preset thresholds are crossed.

Once in the shut-down state, the PDnAll bit in the Power Ctrl register must be set and then cleared to resume normal device operation.

Referenced Control	Register Location
PDnAll	"Power Down (PDnAll)" on page 81

6.2 Hardware Mode

A limited feature set is available when the CS4525 powers up in hardware mode. The available features are described in the following sections. All device configuration is achieved via hardware control input pins.

6.2.1 System Clocking

In hardware mode, the CS4525 must be clocked by a stable external clock source input on the SYS_CLK pin. This input clock is used to synchronize the input serial audio signals with the internal clock domain and to clock the internal digital processing, sample-rate converter, and PWM modulators. It is also used to determine the sample rate of the serial audio input signals in order to automatically configure the various internal filter coefficients.

To ensure proper operation, the CS4525 must be informed of the nominal frequency of the supplied SYS_CLK signal via the ClkFreq[1:0] hardware control pins. These pins must be set to the appropriate level before the $\overline{\text{RST}}$ signal is released to initiate a power-up sequence. The nominal clock frequencies indicated by the states of the ClkFreq[1:0] pins are shown in Table 10 below. See the [SYS_CLK Switching Specifications](#) table on page 23 for complete input frequency range specifications.

ClkFreq1	ClkFreq0	Nominal SYS_CLK Frequency
Low	Low	18.432 MHz
Low	High	24.576 MHz
High	Low	27.000 MHz
High	High	Reserved

Table 10. SYS_CLOCK Frequency Selection

Figure 12 below demonstrates a typical clocking configuration using the SYS_CLK input.

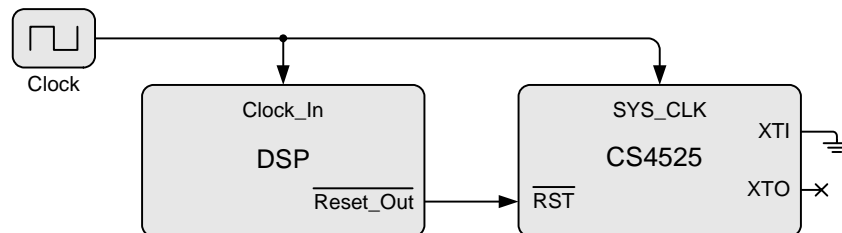

Figure 21. Typical SYS_CLK Input Clocking Configuration

6.2.2 Power-Up and Power-Down

The CS4525 will remain in a completely powered-down state until the $\overline{\text{RST}}$ pin is brought high.

6.2.2.1 Recommended Power-Up Sequence

1. Hold $\overline{\text{RST}}$ low until the power supplies and the input SYS_CLK signal are stable.
2. Bring $\overline{\text{RST}}$ high.
Hardware mode will be entered after approximately 10 ms.

6.2.2.2 Recommended Power-Down Sequence

1. Bring $\overline{\text{MUTE}}$ low to mute the device's outputs and minimize audible pops.
2. Bring $\overline{\text{RST}}$ low to halt the operation of the device.
The device's power consumption will be brought to an absolute minimum.
3. Remove power.

6.2.3 Input Source Selection

The CS4525 can accept analog or digital audio input signals. Digital audio input signals are supplied through the serial audio input port as outlined in “Serial Audio Interfaces” on page 57. Analog audio input signals are supplied through the internal ADC as outlined in “Analog Inputs” on page 56. The input source is selected by the ADC/SP pin as shown in Table 11 below and can be changed at any time without causing any audible pops or clicks.

ADC/SP	Selected Input Source
Low	Digital Audio Inputs (Serial Port)
High	Analog Audio Inputs (ADC)

Table 11. Input Source Selection

In hardware mode, the serial audio input port supports both I²S and left-justified formats. The serial audio interface format is selected by the I2S/LJ pin as shown in Table 12 below.

I2S/LJ	Selected Serial Audio Interface Format
Low	Left-Justified
High	I ² S

Table 12. Serial Audio Interface Format Selection

6.2.4 PWM Channel Delay

In hardware mode, the CS4525 offsets the PWM switching edges between channels as a method of managing switching noise and reducing radiated emissions.

The OUT3/OUT4 signal pair is delayed from the OUT1/OUT2 signal pair by 4 SYS_CLK cycles as shown in Figure 22 below. The absolute delay time is calculated by multiplying the period SYS_CLK by 4.

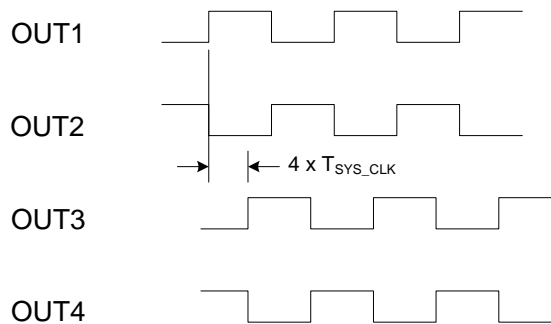

Figure 22. Hardware Mode PWM Output Delay

6.2.5 Digital Signal Flow

In hardware mode, the CS4525 operates as a 2-channel full-bridge PWM amplifier with analog or digital inputs. To protect against over-temperature conditions, thermal foldback is included for the internal power stages.

The digital signal flow is shown in [Figure 14](#) below.

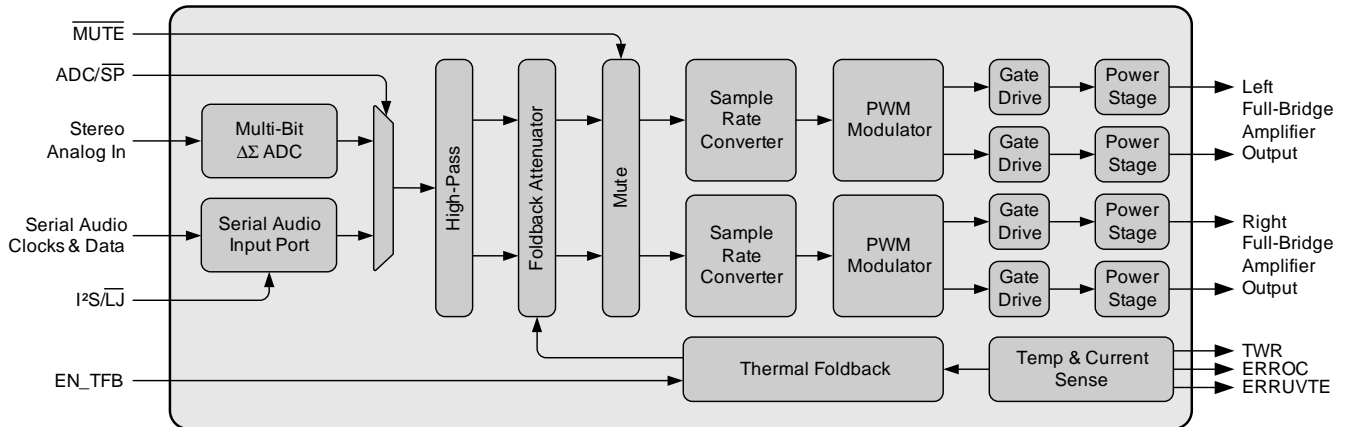

Figure 23. Hardware Mode Digital Signal Flow

6.2.5.1 High-Pass Filter

The CS4525 includes a high-pass filter at the beginning of the digital signal processing chain to remove any DC content from the input signal prior to the remaining internal digital signal processing blocks. The high-pass filter operates by continuously subtracting a measure of the DC offset from the input signal; it is always enabled.

6.2.5.2 Mute Control

The CS4525 includes a dedicated $\overline{\text{MUTE}}$ input pin. When low, the PWM outputs will output silence as an exact non-modulated 50% duty cycle signal. When high, the selected input source will be presented at the amplifier outputs.

It should be noted that the auto-mute, soft-ramp, and zero-crossing detection features available in software mode are disabled in hardware mode.

6.2.5.3 Warning and Error Reporting

The CS4525 is capable of reporting various error and warning conditions on its $\overline{\text{TWR}}$, $\overline{\text{ERROC}}$, and $\overline{\text{ERRUVTE}}$ pins.

- The $\overline{\text{TWR}}$ pin indicates the presence of a thermal warning condition. When active concurrently with the $\overline{\text{ERRUVTE}}$ pin, indicates a thermal error condition.
- The $\overline{\text{ERROC}}$ pin indicates the presence of an over-current condition on one or both of the output channels.
- The $\overline{\text{ERRUVTE}}$ pin indicates the presence of a VP undervoltage or thermal error condition.

The trip point for each warning and error condition is defined in the [PWM Power Output Characteristics](#) table on [page 20](#). Each pin implements an active-low open-drain driver and requires an external pull-up for proper operation.

6.2.6 Thermal Foldback

In hardware mode, the CS4525 implements a thermal foldback feature to guard against damaging thermal overload conditions. The thermal foldback feature begins limiting the volume of the digital audio input to the amplifier stage as the junction temperatures rise above the maximum safe operating range specified by the thermal warning trip point listed in the [PWM Power Output Characteristics](#) table on [page 20](#). This effectively limits the output power capability of the device, thereby allowing the temperature to reduce to acceptable levels without fully interrupting operation. As the device cools, the applied attenuation is gradually released until a new thermal equilibrium is reached or all applied attenuation has been released thereby allowing the device to again achieve its full output power capability.

Attenuation applied due to thermal foldback reduces the audio output level in a linear manner. [Figure 18](#) below demonstrates the foldback process.

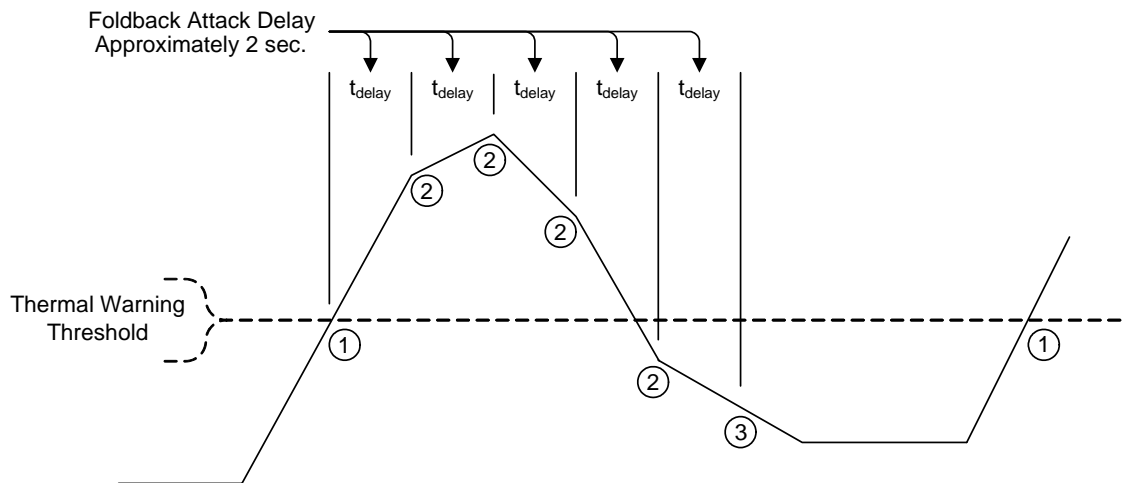

- ① When the junction temperature crosses the thermal warning threshold, the foldback attack delay timer is started.
- ② When the foldback attack delay timer reaches t_{delay} seconds, the junction temperature is checked. If it is above the thermal warning threshold, the output volume level is lowered by 0.5 dB and the foldback attack timer is restarted.
The junction temperature is checked after each foldback attack timer timeout, and if necessary, the output volume level is lowered accordingly.
If the junction temperature is found to be below the thermal warning threshold, the foldback attack timer is restarted once again, but the output volume level is not altered. The foldback algorithm then proceeds to step 3.
- ③ The junction temperature is checked once again after the next foldback attack timer timeout. If it has remained below the thermal warning threshold since the last check, the device will begin to release any attenuation applied as a result of the foldback event.

If the junction temperature crosses the thermal warning threshold again, the foldback algorithm will once again enter step 1.

Figure 24. Foldback Process

Thermal warning conditions will only affect the foldback algorithm and cause attenuation to be applied if enabled by the EN_TFB pin as shown in [Table 13](#) below.

EN_TFB	Selected Thermal Foldback Enable State
Low	Thermal foldback disabled.
High	Thermal foldback enabled.

Table 13. Thermal Foldback Enable Selection

6.2.7 Automatic Power Stage Shut-Down

To protect itself from permanent damage, the CS4525 will automatically shut down its internal PWM power output stages when a thermal error, PWM power output over-current error, or VP under-voltage condition occurs. In the shut-down state, all digital functions of the device will operate as normal, however the PWM power output pins become high-impedance.

The levels of the over-current error, thermal error, and VP under-voltage trip points are listed in the [PWM Power Output Characteristics](#) table on [page 20](#). Automatic shut-down will occur whenever any of these preset thresholds are crossed.

Once in the shut-down state, the $\overline{\text{RST}}$ signal must be toggled low and then high to resume normal device operation.

6.3 PWM Modulators and Sample Rate Converters

The CS4525 includes 3 pairs of PWM modulators and sample rate converters, each clocked from the external crystal or system clock applied at power-up. All 3 modulator and sample rate converter pairs are available in software mode (see [Figure 14 on page 29](#)), and 2 pairs are used in hardware mode (see [Figure 23 on page 51](#)).

One of the characteristics of a PWM modulator is that the frequency content of the out-of-band noise generated is dependent on the PWM switching frequency. As the power stage external LC and snubber filter component values are used to attenuate this out-of-band energy, their component values are also based on this switching frequency.

To easily accommodate input sample rates ranging from 32 kHz to 96 kHz without requiring the adjustment of output filter component values, the CS4525 utilizes a sample rate converter (SRC) to keep the PWM switching frequency fixed regardless of the input sample rate. The SRC operates by upsampling the variable input sample rate to a fixed output switching rate, typically 384 kHz for most audio applications. [Table 14](#) below shows the PWM output switching rate and quantization levels as a function of the supplied external crystal or system clock.

Additionally, as the output of the SRC is clocked from a very stable crystal or oscillator, the SRC also allows the PWM modulator output to be independent of the input serial audio clock jitter. This results in very low jitter PWM output and higher dynamic range.

Supplied XTAL or SYS_CLK Frequency	PWM Switch Rate	Quantization Levels
18.432 MHz	384 kHz	48
24.576 MHz	384 kHz	64
27.000 MHz	421.875 kHz	64

Table 14. PWM Output Switching Rates and Quantization Levels

6.4 Output Filters

The filter placed after the PWM outputs can greatly affect the output performance. The filter not only reduces radiated EMI (snubber filter), but also filters high frequency content from the switching output before going to the speaker (low-pass LC filter).

6.4.1 Half-Bridge Output Filter

Figure 25 shows the output filter for a half-bridge configuration. The transient-voltage suppression circuit (snubber circuit) is comprised of a resistor ($20\ \Omega$, $\frac{1}{4}\text{ W}$) and capacitors ($220\ \text{pF}$) and should be placed as close as possible to the corresponding PWM output pin to greatly reduce radiated EMI.

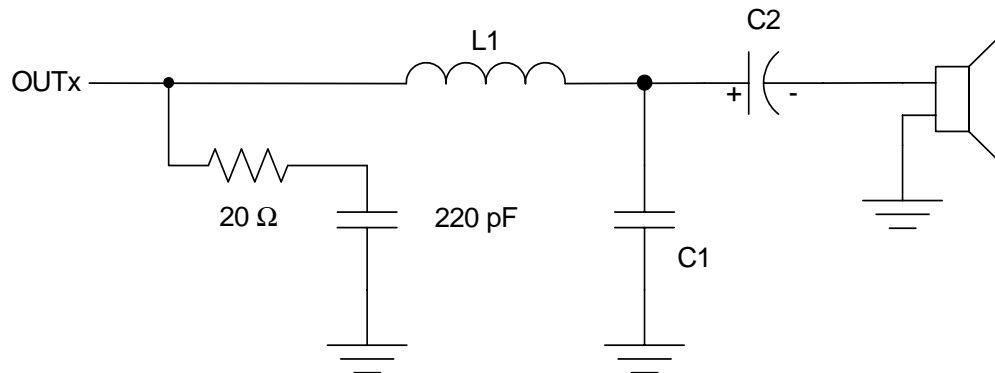

Figure 25. Output Filter - Half-Bridge

The inductor, L1, and capacitor, C1, comprise the low-pass filter. Along with the nominal load impedance of the speaker, these values set the cutoff frequency of the filter. Table 15 shows the component values for L1 and C1 based on nominal speaker (load) impedance for a corner frequency (-3 dB point) of approximately 35 kHz.

Load	L1	C1
4 Ω	22 μH	1.0 μF
6 Ω	33 μH	0.68 μF
8 Ω	47 μH	0.47 μF

Table 15. Low-Pass Filter Components - Half-Bridge

C2 is the DC-blocking capacitor. Table 16 shows the component values for C2 based on corner frequency (-3 dB point) and a nominal speaker (load) impedances of 4 Ω , 6 Ω , and 8 Ω . This capacitor should also be chosen to have a ripple current rating above the amount of current that will be passed through it.

Load	Corner Frequency	C2
4 Ω	40 Hz	1000 μF
	58 Hz	680 μF
	120 Hz	330 μF
6 Ω	39 Hz	680 μF
	68 Hz	390 μF
	120 Hz	220 μF
8 Ω	42 Hz	470 μF
	60 Hz	330 μF
	110 Hz	180 μF

Table 16. DC-Blocking Capacitors Values - Half-Bridge

6.4.2 Full-Bridge Output Filter (Stereo or Parallel)

Figure 26 shows the output filter for a full-bridge configuration. The transient-voltage suppression circuit (snubber circuit) is comprised of a resistor (20 Ω) and capacitor (330 pF) and should be placed as close as possible to the corresponding PWM output pins to greatly reduce radiated EMI. The inductors, L1, and capacitor, C1, comprise the low-pass filter. Along with the nominal load impedance of the speaker, these values set the cutoff frequency of the filter. Table 17 shows the component values based on nominal speaker (load) impedance for a corner frequency (-3 dB point) of approximately 35 kHz.

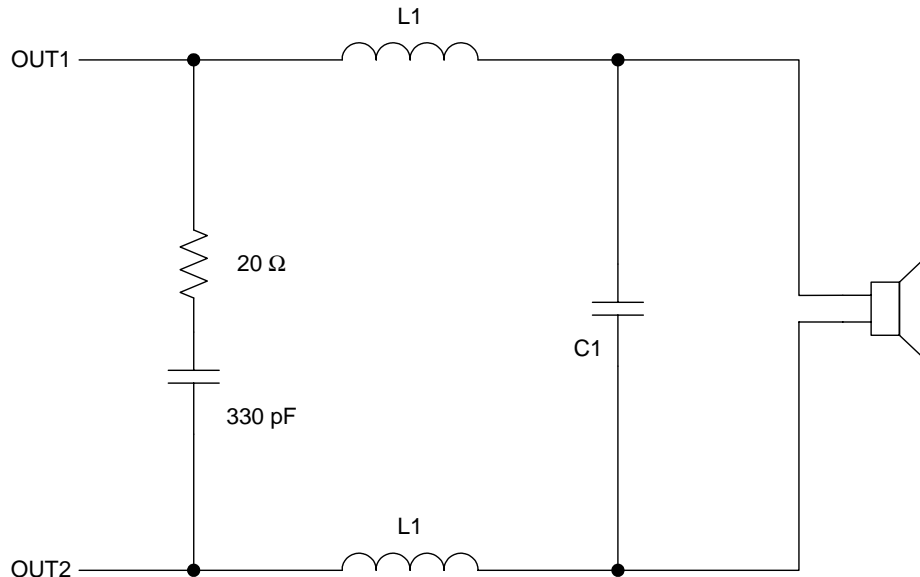

Figure 26. Output Filter - Full-Bridge

Load	L1	C1
4 Ω	10 μ H	1.0 μ F
6 Ω	15 μ H	0.47 μ F
8 Ω	22 μ H	0.47 μ F

Table 17. Low-Pass Filter Components - Full-Bridge

6.5 Analog Inputs

Very few components are required to interface between the audio source and the CS4525's analog inputs, AINL and AINR. A single order passive low-pass filter is recommended to prevent high-frequency content from aliasing into the audio band due to the analog-to-digital conversion process. Also, a DC-blocking capacitor is required as the CS4525's analog inputs are internally biased to V_Q.

The recommended analog input circuit is shown in [Figure 27](#) below will accommodate full-scale input voltages as defined in the [Analog Input Characteristics](#) table on [page 19](#). This circuit provides the necessary high-frequency filtering with a first-order passive low-pass filter that has less than 0.05 dB of attenuation at 24 kHz. It also includes a DC blocking capacitor to accommodate the analog input pins' bias level.

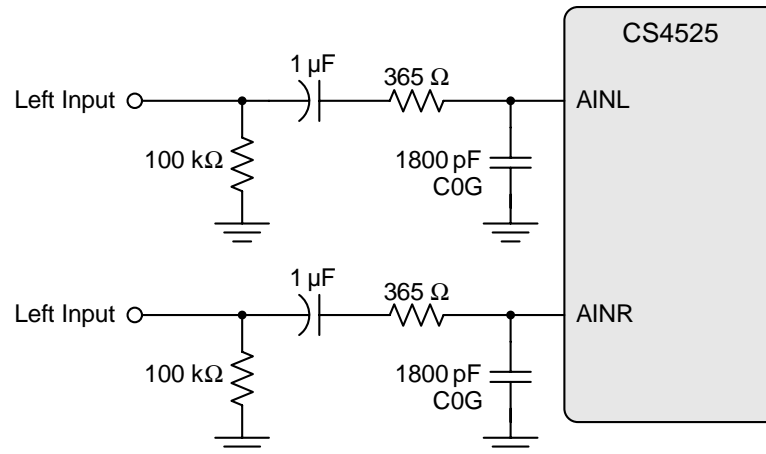

Figure 27. Recommended Unity Gain Input Filter

To interface 2 V_{RMS} input signals with the CS4525's analog inputs, an external resistor divider is required. [Figure 28](#) shows the recommended input circuit for 2 V_{RMS} inputs. It includes a -10.5 dB passive attenuator to condition the input signal for the CS4525's full-scale input voltage, a first-order passive low-pass filter that has less than 0.05 dB of attenuation at 24 kHz, and a DC blocking capacitor to accommodate for the analog input pins' bias level. The passive attenuator network should be placed as close as possible to the CS4525's analog input pins to reduce the potential for noise and signal coupling into the analog input traces.

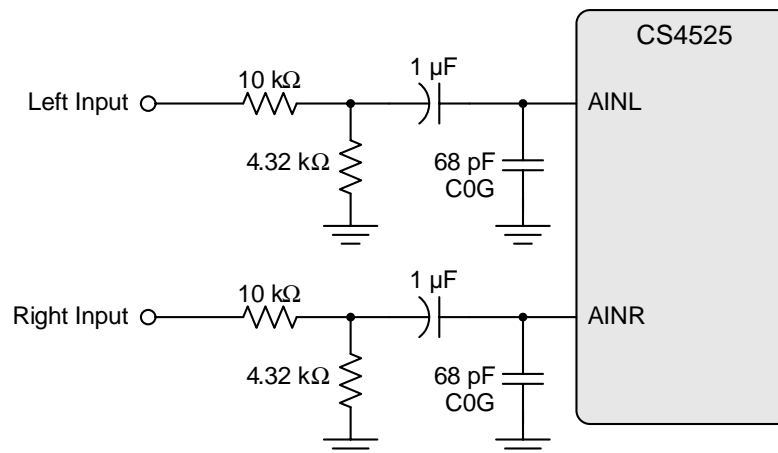

Figure 28. Recommended 2 V_{RMS} Input Filter

It should be noted that the external DC blocking capacitor forms a high-pass filter with the CS4525's input impedance. Both filters shown above have less than 0.2 dB attenuation at 20 Hz due to this effect. Increasing the value of this capacitor will lower this high-pass corner frequency, and decreasing its value will increase the corner frequency.

6.6 Serial Audio Interfaces

The CS4525 interfaces to external digital audio devices via the serial audio input port and the auxiliary/delay serial ports.

The serial audio input port provides support for I²S, Left-Justified and Right-Justified data formats and operates in slave mode only, with LRCK and SCLK as inputs. The input LRCK signal must be equal to the sample rate, F_s and must be synchronous to the serial bit clock, SCLK, which is used to sample the data bits.

The auxiliary/delay serial port (available in software mode only) supports I²S and Left-Justified data formats and operates in master mode, with AUX_LRCK and AUX_SCLK as outputs.

Each of the supported formats is described in detail in sections 6.6.1 - 6.6.3 below.

For additional information, application note AN282 presents a tutorial of the 2-channel serial audio interface. AN282 can be downloaded from the Cirrus Logic web site at <http://www.cirrus.com>.

6.6.1 I²S Data Format

In I²S format, data is received most significant bit first one SCLK delay after the transition of LRCK and is valid on the rising edge of SCLK. The left channel data is presented when LRCK is low; the right channel data is presented when LRCK is high.

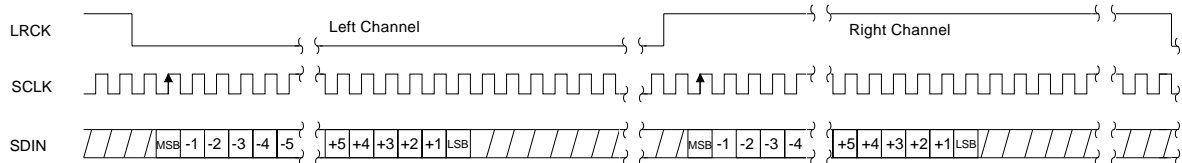

I ² S Mode, Data Valid on Rising Edge of SCLK	
Bits/Sample	SCLK Rates
16	32, 48, 64, 128 F_s
18 to 24	48, 64, 128 F_s

Figure 29. I²S Serial Audio Formats

6.6.2 Left-Justified Data Format

In Left-Justified format, data is received most significant bit first on the first SCLK after a LRCK transition and is valid on the rising edge of SCLK. The left channel data is presented when LRCK is high and the right channel data is presented when LRCK is low.

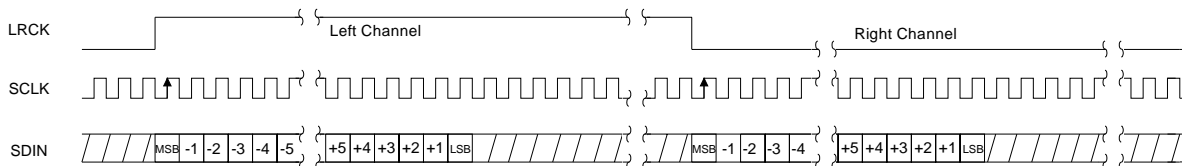

Left-Justified Mode, Data Valid on Rising Edge of SCLK	
Bits/Sample	SCLK Rate(s)
16	32, 48, 64, 128 F_s
18 to 24	48, 64, 128 F_s

Figure 30. Left-Justified Serial Audio Formats

6.6.3 Right-Justified Data Format

In Right-Justified format, data is received most significant bit first and with the least significant bit presented on the last SCLK before the LRCK transition and is valid on the rising edge of SCLK. For the Right-Justified format, the left channel data is presented when LRCK is high and the right channel data is presented when LRCK is low. Either 16 bits per sample or 24 bits per sample are supported.

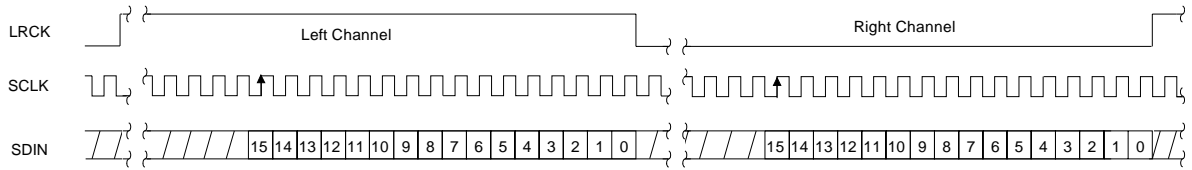

Right-Justified Mode, Data Valid on Rising Edge of SCLK	
Bits/Sample	Supported SCLK Rate(s)
16	32, 48, 64, 128 Fs
24	48, 64, 128 Fs

Figure 31. Right-Justified Serial Audio Formats

6.7 I²C Control Port Description and Timing

The control port is used to access the registers allowing the CS4525 to be configured for the desired operational modes and formats. The operation of the control port may be completely asynchronous with respect to the audio sample serial port. However, to avoid potential interference problems, the control port pins should remain static if no operation is required. The control port operates in I²C Mode, with the CS4525 acting as a slave device.

SDA is a bidirectional data line. Data is clocked into and out of the part by the clock, SCL. A 47 kΩ pull-up or pull-down on the AUX_LRCK/AD0 pin will set AD0, the least significant bit of the chip address. A pull-up to VD will set AD0 to '1' and a pull-down to DGND will set AD0 to '0'. The state of AUX_LRCK/AD0 is sensed, and AD0 is set upon the release of RESET.

The signal timings for a read and write cycle are shown in [Figure 32](#) and [Figure 25](#). A Start condition is defined as a falling transition of SDA while the clock is high. A Stop condition is a rising transition while the clock is high. All other transitions of SDA occur while the clock is low. The first byte sent to the CS4525 after a Start condition consists of a 7 bit chip address field and a R/W bit (high for a read, low for a write). The upper 6 bits of the 7-bit address field are fixed at 100101. To communicate with a CS4525, the chip address field, which is the first byte sent to the CS4525, should match 100101 followed by the setting of AD0. The eighth bit of the address is the R/W bit. If the operation is a write, the next byte is the memory address pointer (MAP) which selects the register to be read or written. If the operation is a read, the contents of the register pointed to by the MAP will be output. Setting the auto increment bit in MAP allows successive reads or writes of consecutive registers. Each byte is separated by an acknowledge bit. The ACK bit is output from the CS4525 after each input byte is read, and is input to the CS4525 from the microcontroller after each transmitted byte.

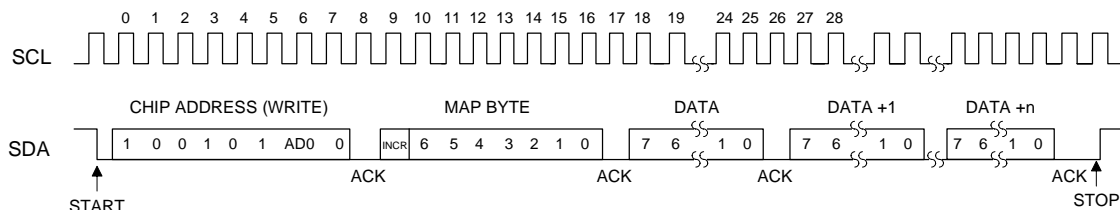

Figure 32. Control Port Timing, I²C Write

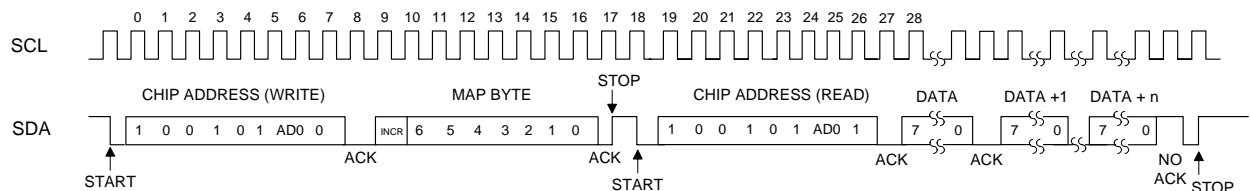

Figure 33. Control Port Timing, I²C Read

Since the read operation can not set the MAP, an aborted write operation is used as a preamble. As shown in [Figure 25](#), the write operation is aborted after the acknowledge for the MAP byte by sending a stop condition. The following pseudocode illustrates an aborted write operation followed by a read operation.

- Send start condition.
- Send 100101x0 (chip address & write operation).
- Receive acknowledge bit.
- Send MAP byte, auto increment off.
- Receive acknowledge bit.
- Send stop condition, aborting write.
- Send start condition.
- Send 100101x1 (chip address & read operation).

- Receive acknowledge bit.
- Receive byte, contents of selected register.
- Send acknowledge bit.
- Send stop condition.

Setting the auto increment bit in the MAP allows successive reads or writes of consecutive registers. Each byte is separated by an acknowledge bit.

7. PCB LAYOUT CONSIDERATIONS

7.1 Power Supply, Grounding

As with any high-resolution converter, the CS4525 requires careful attention to power supply and grounding arrangements if its potential performance is to be realized.

Extensive use of power and ground planes, ground plane fill in unused areas and surface mount decoupling capacitors are recommended. Decoupling capacitors should be as close to the pins of the CS4525 as possible. The lowest value ceramic capacitor should be closest to the pin and should be mounted on the same side of the board as the CS4525 to minimize inductance effects. All signals, especially clocks, should be kept away from the FILT+ and VQ pins in order to avoid unwanted coupling into the modulators. The FILT+ and VQ decoupling capacitors, particularly the 0.1 μF , must be positioned to minimize the electrical path from FILT+ and AGND. The CRD4525 reference design demonstrates the optimum layout and power supply arrangements.

7.1.1 Integrated VD Regulator

The CS4525 includes two internal linear regulators, one from the VD supply voltage to provide a fixed 2.5 - V supply to its internal digital blocks, and another from the VD supply voltage to provide a fixed 2.5 - V supply to its internal analog blocks. The LVD pin must be set to indicate the voltage present on the VD pin as shown in Table 18 below.

LVD	Indicated VD Supply Level
Low	2.5 V or 3.3 V Nominal
High	5 V Nominal

Table 18. Input Source Selection

The output of the digital regulator is presented on the VD_REG pin and may be used to provide an external device with up to 3 mA of current at its nominal output voltage of 2.5 - V. The output of the analog regulator is presented on the VA_REG pin and must only be connected to the bypass capacitors as shown in the typical connection diagrams.

If a nominal supply voltage of 2.5 V is used as the VD supply (see the Specified Operating Conditions table on page 18), the VD, VD_REG, and VA_REG pins must all be connected to the VD supply source. In this configuration, the internal regulators are bypassed and the external supply source is used to directly drive the internal digital and analog sections.

7.2 QFN Thermal Pad

The CS4525 is available in a compact QFN package. The underside of the QFN package reveals a large metal pad that serves as a thermal relief to provide for maximum heat dissipation. This pad must mate with an equally dimensioned copper pad on the PCB and must be electrically connected to ground. A series of thermal vias should be used to connect this copper pad to one or more larger ground planes on other PCB layers. The CRD4525 reference design demonstrates the optimum thermal pad and via configuration.

8. REGISTER QUICK REFERENCE

This table shows the register names and their associated default values.

Adr	Name	7	6	5	4	3	2	1	0	
01h	Clock Config page 64	EnSysClk 1	DivSysClk 0	ClkFreq1 0	ClkFreq0 1	HP/MutePol 0	HP/Mute 0	PhaseShift 0	FreqShift 0	
02h	Input Config page 66	ADC/SP 0	EnAnHPF 1	Reserved 0	SPRate1 x	SPRate0 x	DIF2 0	DIF1 0	DIF0 0	
03h	Aux Config page 67	EnAuxPort 0	DlyPortCfg1 0	DlyPortCfg0 0	AuxI ² S/LJ 0	RChDSel1 0	RChDSel0 1	LChDSel1 0	LChDSel0 0	
04h	Output Cfg page 68	OutputCfg1 0	OutputCfg0 0	PWMDSel1 0	PWMDSel0 0	OutputDly3 0	OutputDly2 0	OutputDly1 0	OutputDly0 0	
05h	Foldback Cfg page 69	Reserved 0	EnTherm 0	LockAdj 0	AttackDly1 0	AttackDly0 1	EnFloor 0	RmpSpd1 1	RmpSpd0 1	
06h	Mixer Config page 70	PreScale2 0	PreScale1 0	PreScale0 0	Reserved 0	RChMix1 0	RChMix0 0	LChMix1 0	LChMix0 0	
07h	Tone Config page 71	DeEmph 0	Loudness 0	EnDigHPF 0	TrebFc1 0	TrebFc0 0	BassFc1 0	BassFc0 1	EnToneCtrl 0	
08h	Tone Control page 72	Treble3 1	Treble2 0	Treble1 0	Treble0 0	Bass3 1	Bass2 0	Bass1 0	Bass0 0	
09h	EQ Config page 73	Freeze 0	Reserved 0	BassMgr2 0	BassMgr1 0	BassMgr0 0	EnLFEPEq 0	EnChBPEq 0	EnChAPEq 0	
0Ah	Channel 1&2	MSB							MSB-7	
0Bh	BiQuad 1	MSB-8							LSB+8	
0Ch	A1 Coeff	LSB+7							LSB	
0Dh	Channel 1&2	MSB							MSB-7	
0Eh	BiQuad 1	MSB-8							LSB+8	
0Fh	A2 Coeff	LSB+7							LSB	
10h	Channel 1&2	MSB							MSB-7	
11h	BiQuad 1	MSB-8							LSB+8	
12h	B0 Coeff	LSB+7							LSB	
13h	Channel 1&2	MSB							MSB-7	
14h	BiQuad 1	MSB-8							LSB+8	
15h	B1 Coeff	LSB+7							LSB	
16h	Channel 1&2	MSB							MSB-7	
17h	BiQuad 1	MSB-8							LSB+8	
18h	B2 Coeff	LSB+7							LSB	
19h	Channel 1&2	MSB							MSB-7	
1Ah	BiQuad 2	MSB-8							LSB+8	
1Bh	A1 Coeff	LSB+7							LSB	
1Ch	Channel 1&2	MSB							MSB-7	
1Dh	BiQuad 2	MSB-8							LSB+8	
1Eh	A2 Coeff	LSB+7							LSB	
1Fh	Channel 1&2	MSB							MSB-7	
20h	BiQuad 2	MSB-8							LSB+8	
21h	B0 Coeff	LSB+7							LSB	
22h	Channel 1&2	MSB							MSB-7	
23h	BiQuad 2	MSB-8							LSB+8	
24h	B1 Coeff	LSB+7							LSB	

Adr	Name	7	6	5	4	3	2	1	0
25h	Channel 1&2	MSB						MSB-7
26h	BiQuad 2	MSB-8						LSB+8
27h	B2 Coeff	LSB+7						LSB
28h	Channel 1&2	MSB						MSB-7
29h	BiQuad 3	MSB-8						LSB+8
2Ah	A1 Coeff	LSB+7						LSB
2Bh	Channel 1&2	MSB						MSB-7
2Ch	BiQuad 3	MSB-8						LSB+8
2Dh	A2 Coeff	LSB+7						LSB
2Eh	Channel 1&2	MSB						MSB-7
2Fh	BiQuad 3	MSB-8						LSB+8
30h	B0 Coeff	LSB+7						LSB
31h	Channel 1&2	MSB						MSB-7
32h	BiQuad 3	MSB-8						LSB+8
33h	B1 Coeff	LSB+7						LSB
34h	Channel 1&2	MSB						MSB-7
35h	BiQuad 3	MSB-8						LSB+8
36h	B2 Coeff	LSB+7						LSB
37h	Channel 3	MSB						MSB-7
38h	BiQuad 1	MSB-8						LSB+8
39h	A1 Coeff	LSB+7						LSB
3Ah	Channel 3	MSB						MSB-7
3Bh	BiQuad 1	MSB-8						LSB+8
3Ch	A2 Coeff	LSB+7						LSB
3Dh	Channel 3	MSB						MSB-7
3Eh	BiQuad 1	MSB-8						LSB+8
3Fh	B0 Coeff	LSB+7						LSB
40h	Channel 3	MSB						MSB-7
41h	BiQuad 1	MSB-8						LSB+8
42h	B1 Coeff	LSB+7						LSB
43h	Channel 3	MSB						MSB-7
44h	BiQuad 1	MSB-8						LSB+8
45h	B2 Coeff	LSB+7						LSB
46h	Channel 3	MSB						MSB-7
47h	BiQuad 2	MSB-8						LSB+8
48h	A1 Coeff	LSB+7						LSB
49h	Channel 3	MSB						MSB-7
4Ah	BiQuad 2	MSB-8						LSB+8
4Bh	A2 Coeff	LSB+7						LSB
4Ch	Channel 3	MSB						MSB-7
4Dh	BiQuad 2	MSB-8						LSB+8
4Eh	B0 Coeff	LSB+7						LSB
4Fh	Channel 3	MSB						MSB-7
50h	BiQuad 2	MSB-8						LSB+8
51h	B1 Coeff	LSB+7						LSB
52h	Channel 3	MSB						MSB-7
53h	BiQuad 2	MSB-8						LSB+8
54h	B2 Coeff	LSB+7						LSB

Adr	Name	7	6	5	4	3	2	1	0
55h	Volume Cfg page 75	SZCMode1 1	SZCMode0 0	Mute50/50 0	AutoMute 1	En2Way 0	2WayFreq2 0	2WayFreq1 0	2WayFreq0 0
56h	Sensitivity page 76	LowPass3 0	LowPass2 0	LowPass1 0	LowPass0 0	HighPass3 0	HighPass2 0	HighPass1 0	HighPass0 0
57h	Master Vol page 77	MVol7 0	MVol6 0	MVol5 1	MVol4 1	MVol3 0	MVol2 0	MVol1 0	MVol0 0
58h	Ch 1 Vol page 78	Ch1Vol7 0	Ch1Vol6 0	Ch1Vol5 1	Ch1Vol4 1	Ch1Vol3 0	Ch1Vol2 0	Ch1Vol1 0	Ch1Vol0 0
59h	Ch 2 Vol page 78	Ch2Vol7 0	Ch2Vol6 0	Ch2Vol5 1	Ch2Vol4 1	Ch2Vol3 0	Ch2Vol2 0	Ch2Vol1 0	Ch2Vol0 0
5Ah	Ch 3 Vol page 78	Ch3Vol7 0	Ch3Vol6 0	Ch3Vol5 1	Ch3Vol4 1	Ch3Vol3 0	Ch3Vol2 0	Ch3Vol1 0	Ch3Vol0 0
5Bh	Mute Control page 78	InvADC 0	InvCh3 0	InvCh2 0	InvCh1 0	MuteADC 0	MuteCh3 0	MuteCh2 0	MuteCh1 0
5Ch	Limiter Cfg 1 page 79	Max2 0	Max1 0	Max0 0	Min2 0	Min1 0	Min0 0	LimitAll 1	EnLimiter 0
5Dh	Limiter Cfg 2 page 80	Reserved 0	Reserved 0	RRate5 1	RRate4 1	RRate3 1	RRate2 1	RRate1 1	RRate0 1
5Eh	Limiter Cfg 3 page 80	Reserved 0	Reserved 0	ARate5 0	ARate4 0	ARate3 0	ARate2 0	ARate1 0	ARate0 0
5Fh	Power Ctrl page 81	Reserved 0	Reserved 1	SelectVD 1	PDnADC 1	PDnOut3/4 1	PDnOut2 1	PDnOut1 1	PDnAll 1
60h	Interrupt page 82	SRCLock x	ADCOvfl x	ChOvfl x	AmpErr x	SRCLockM 0	ADCOvflM 0	ChOvflM 0	AmpErrM 0
61h	Int Status page 84	SRCLockSt x	ADCOvflSt x	Ch3OvflSt x	Ch2OvflSt x	Ch1OvflSt x	RampDone x	Reserved 0	Reserved 0
62h	Amp Error page 85	OverCurr4 x	OverCurr3 x	OverCurr2 x	OverCurr1 x	ExtAmpSt x	UnderV x	ThermErr x	ThermWarn x
63h	Device ID page 87	DeviceID4 1	DeviceID3 1	DeviceID2 0	DeviceID1 0	DeviceID0 0	RevID2 x	RevID1 x	RevID0 x

9. REGISTER DESCRIPTIONS

All registers are read/write unless otherwise stated. All “Reserved” bits must maintain their default state.

9.1 Clock Configuration (Address 01h)

7	6	5	4	3	2	1	0
EnSysClk	DivSysClk	ClkFreq1	ClkFreq0	HP/MutePol	HP/Mute	PhaseShift	FreqShift

9.1.1 SYS_CLK Output Enable (EnSysClk)

Default = 1

Function:

This bit controls the output driver for the SYS_CLK signal. When cleared, the output driver is disabled and the SYS_CLK pin is high-impedance. When set, the output driver is enabled.

If the SYS_CLK output is unused, this bit should be set to ‘0’b to disable the driver.

EnSysClk Setting	Output Driver State
0	Output driver disabled.
1	Output driver enabled.

9.1.2 SYS_CLK Output Divider (DivSysClk)

Default = 0

Function:

This bit determines the divider for the XTAL clock signal for generating the SYS_CLK signal.

This divider is only available if the clock source is an external crystal attached to XTI/XTO and the SYS_CLK output is enabled.

DivSysClk Setting	SYS_CLK Output Frequency
0	$F_{\text{SYS_CLK}} = F_{\text{XTAL}}$
1	$F_{\text{SYS_CLK}} = F_{\text{XTAL}}/2$

9.1.3 Clock Frequency (ClkFreq[1:0])

Default = 01

Function:

These bits must be set to identify the nominal clock frequency of the crystal attached to the XTI/XTO pins or that of the input SYS_CLK signal. See the [XTI Switching Specifications](#) table on [page 23](#) and the [SYS_CLK Switching Specifications](#) table on [page 23](#) for complete input frequency range specifications.

ClkFreq[1:0] Setting	Specified Nominal Input Clock Frequency
00	18.432 MHz
01	24.576 MHz
10	27.000 MHz
11	Reserved

9.1.4 HP_Detect/Mute Pin Active Logic Level (HP/MutePol)

Default = 0

Function:

This bit determines the active logic level for the HP_DETECT/MUTE input signal.

HP/MutePol Setting	Headphone Detect/Mute Input Polarity
0	Active low.
1	Active high.

9.1.5 HP_Detect/Mute Pin Mode (HP/Mute)

Default = 0

Function:

Configures the function of HP_DETECT/MUTE input pin. See [“Headphone Detection & Hardware Mute Input” on page 47](#) for more information.

HP/Mute Setting	HP_DETECT/MUTE Pin Function
0	Mute input signal.
1	Headphone detect input signal.

9.1.6 Modulator Phase Shifting (PhaseShift)

Default = 0

Function:

When enabled, forces the output of the PWM modulator to output differential signals which are the inverse of each other and have been phase shifted by 180 degrees. This causes, for instance, the differential signal pair to be exactly in phase with one another during a mute condition, thereby reducing the amount of switching current through the load.

PhaseShift Setting	Modulator Phase Shift State
0	180° phase shift disabled.
1	180° phase shift enabled.

9.1.7 AM Frequency Shifting (FreqShift)

Default = 0

Function:

Controls the state of the PWM AM frequency shift feature. See [“PWM AM Frequency Shift” on page 47](#) for more information.

FreqShift Setting	AM Frequency Shift State
0	Frequency shift disabled.
1	Frequency shift enabled.

9.2 Input Configuration (Address 02h)

7	6	5	4	3	2	1	0
ADC/SP	EnAnHPF	Reserved	SPRate1	SPRate0	DIF2	DIF1	DIF0

9.2.1 Input Source Selection (ADC/SP)

Default = 0

Function:

This bit selects the audio input source.

ADC/SP Setting	Audio Input Source
0	Digital input from the serial audio input port.
1	Analog input from the internal ADC.

9.2.2 ADC High-Pass Filter Enable (EnAnHPF)

Default = 1

Function:

Controls the operation of the ADC high-pass filter.

EnAnHPF Setting	ADC High-Pass Filter State
0	ADC high-pass filter disabled.
1	ADC high-pass filter enabled.

9.2.3 Serial Port Sample Rate (SPRate[1:0]) - Read Only

Default = XX

Function:

Identifies the sample rate of the incoming LRCK signal on the serial audio input port.

SPRate[1:0] Setting	Identified Input Sample Rate
00	32 kHz
01	44.1 kHz
10	48 kHz
11	96 kHz

9.2.4 Input Serial Port Digital Interface Format (DIF [2:0])

Default = 000

Function:

Selects the serial audio interface format used for the data in on SDIN. The required relationship between the Left/Right clock, serial clock and serial data is defined by the Digital Interface Format and the options are detailed in the section “[Serial Audio Interfaces](#)” on page 57.

DIF[2:0] Setting	Input Serial Port Serial Audio Interface Format
000	Left-Justified, up to 24-bit data.
001	I ² S, up to 24-bit data.
010	Right-Justified, 24-bit data.
011	Right-Justified, 20-bit data.
100	Right-Justified, 18-bit data.
101	Right-Justified, 16-bit data.
110	Reserved.
111	Reserved.

9.3 AUX Port Configuration (Address 03h)

7	6	5	4	3	2	1	0
EnAuxPort	DlyPortCfg1	DlyPortCfg0	AuxI ² S/LJ	RChDSel1	RChDSel0	LChDSel1	LChDSel0

9.3.1 Enable Aux Serial Port (EnAuxPort)

Default = 0

Function:

Controls the operation of the auxiliary serial port.

EnAuxPort Setting	Auxiliary Port State
0	Auxiliary port disabled.
1	Auxiliary port enabled.

9.3.2 Delay & Warning Port Configuration (DlyPortCfg[1:0])

Default = 00

Function:

Controls the operation of the delay and warning port. See [“Serial Audio Delay & Warning Input Port”](#) on page 42 for more information.

DlyPortCfg[1:0] Setting	Delay Port Configuration
00	Port disabled.
01	Port configured as serial audio delay interface.
10	Port configured as an external thermal warning indicator for the foldback algorithm.
11	Port disabled.

9.3.3 Aux/Delay Serial Port Digital Interface Format (AuxI²S/LJ)

Default = 0

Function:

Selects the serial audio interface format for the data on AUX_SDOUT, DLY_SDIN, DLY_SDOUT. The required relationship between the Left/Right clock, serial clock and serial data is defined by the Digital Interface Format and the options are detailed in the [“Serial Audio Interfaces”](#) on page 57.

AuxI ² S/LJ Setting	Auxiliary/Delay Port Serial Audio Interface Format
0	Left-Justified, up to 24-bit.
1	I ² S, up to 24-bit.

9.3.4 Aux Serial Port Right Channel Data Select (RChDSel[1:0])

Default = 01

Function:

Selects the data to be sent over the right channel of the auxiliary port serial data output signal.

RChDSel[1:0] Setting	Aux Serial Port Right Channel Output Data Source
00	Channel A.
01	Channel B.
10	LFE Channel.
11	Channel B crossover low-pass output.

9.3.5 Aux Serial Port Left Channel Data Select (LChDSEL[1:0])

Default = 00

Function:

Selects the data to be sent over the left channel of the auxiliary port serial data output signal.

LChDSEL[1:0] Setting	Aux Serial Port Left Channel Output Data Source
00	Channel A.
01	Channel B.
10	LFE Channel.
11	Channel B crossover high-pass output.

9.4 Output Configuration Register (Address 04h)

7	6	5	4	3	2	1	0
OutputCfg1	OutputCfg0	PWMDSEL1	PWMDSEL0	OutputDly3	OutputDly2	OutputDly1	OutputDly0

9.4.1 Output Configuration (OutputCfg[1:0])

Default = 00

Function:

Identifies the power output configuration. This parameter can only be changed when all modulators and associated logic are in the power-down state (the PDnAll bit is set). Attempts to write this register while the PDnAll is cleared will be ignored. See [“PWM Power Output Configurations” on page 43](#) for more information.

OutputCfg[1:0] Setting	Power Output Configuration
00	Channel 1 & 2 Full-Bridge.
01	Channel 1 & 2 Half-Bridge + Channel 3 Full-Bridge.
10	Channel 1 Parallel Full-Bridge.
11	Reserved.

9.4.2 PWM Signals Output Data Select (PWMDSEL[1:0])

Default = 00

Function:

Selects the PWM data output on the PWM_SIG1 and PWM_SIG2 output signals. See [“PWM_SIG Logic-Level Output Configurations” on page 44](#) for more information.

PWMDSEL Setting	PWM Signal Output Mapping
00	PWM_SIG1 output disabled. PWM_SIG2 output disabled.
01	Channel 1 output on PWM_SIG1. Channel 2 output on PWM_SIG2.
10	Channel 1 output on PWM_SIG1. Channel 3 output on PWM_SIG2.
11	Channel 2 output on PWM_SIG1. Channel 3 output on PWM_SIG2.

9.4.3 Channel Delay Settings (OutputDly[3:0])

Default = 0000

Function:

The channel delay bits allow delay adjustment of each of the power output audio channels. The value of this register determines the amount of delay inserted in the output path. The delay time is calculated by multiplying the register value by the period of the SYS_CLK or crystal input clock source. These bits can

only be changed while all modulators and associated logic are in the power-down state (the PDnAll bit is set). Attempts to write these bits while the PDnAll bit is cleared will be ignored. See [“PWM Channel Delay” on page 50](#) for more information.

OutputDly[3:0] Setting	Output Delay in Input Clock Source Cycles
0000	0 - No Delay
0001	1
0010	2
.....
1000	8
.....
1111	15 - Max Delay

9.5 Foldback and Ramp Configuration (Address 05h)

7	6	5	4	3	2	1	0
Reserved	EnTherm	LockAdj	AttackDly1	AttackDly0	EnFloor	RmpSpeed1	RmpSpeed0

9.5.1 Enable Thermal Foldback (EnTherm)

Default = 0

Function:

Enables the thermal foldback feature. See [“Thermal Foldback” on page 39](#) for more information.

EnTherm Setting	Thermal Foldback State
0	Disabled.
1	Enabled.

9.5.2 Lock Foldback Adjust (LockAdj)

Default = 0

Function:

Controls the operation of the foldback lock adjustment feature. See [“Thermal Foldback” on page 39](#) for more information.

LockAdj Setting	Foldback Adjustment Lock State
0	Attenuation lock disabled.
1	Attenuation lock enabled.

9.5.3 Foldback Attack Delay (AttackDly[1:0])

Default = 01

Function:

Controls the foldback attack delay. See [“Thermal Foldback” on page 39](#) for more information.

AttackDly[1:0] Setting	Foldback Attack Time
00	Approximately 0.5 seconds.
01	Approximately 1.0 seconds.
10	Approximately 1.5 seconds.
11	Approximately 2.0 seconds.

9.5.4 Enable Foldback Floor (EnFloor)

Default = 0

Function:

Controls the foldback attenuation floor feature. See [“Thermal Foldback” on page 39](#) for more information.

EnFloor Setting	Attenuation Floor
0	No foldback attenuation floor imposed.
1	Maximum foldback attenuation limited to -30 dB.

9.5.5 Ramp Speed (RmpSpd[1:0])

Default = 11

Function:

Controls the PWM output ramp speed. See [“PWM PopGuard Transient Control” on page 45](#) for more information.

RmpSpd[1:0] Setting	Ramp Speed
00	Approximately 0.70 seconds.
01	Approximately 0.75 seconds.
10	Approximately 0.85 seconds.
11	Immediate. PWM PopGuard Disabled.

9.6 Mixer / Pre-Scale Configuration (Address 06h)

7	6	5	4	3	2	1	0
PreScale2	PreScale1	PreScale0	Reserved	RChMix1	RChMix0	LChMix1	LChMix0

9.6.1 Pre-Scale Attenuation (PreScale[2:0])

Default = 000

Function:

Controls the pre-scale attenuation level. See [“Pre-Scaler” on page 29](#) for more information.

PreScale[2:0] Setting	Pre-Scale Attenuation Setting
000	No pre-scale attenuation applied.
001	-2.0 dB
010	-4.0 dB
.....	
100	-8.0 dB
.....	
111	-14.0 dB

9.6.2 Right Channel Mixer (RChMix[1:0])

Default = 00

Function:

Controls the right channel mixer output. See [“Channel Mixer” on page 30](#) for more information.

RChMix[1:0] Setting	Right Channel Mixer Output on Channel B
00	Right Channel
01	(Left Channel + Right Channel) / 2
10	(Left Channel + Right Channel) / 2
11	Left Channel

9.6.3 Left Channel Mixer (LChMix[1:0])

Default = 00

Function:

Controls the left channel mixer output. See [“Channel Mixer” on page 30](#) for more information.

LChMix[1:0] Setting	Left Channel Mixer Output on Channel A
00	Left Channel
01	(Left Channel + Right Channel) / 2
10	(Left Channel + Right Channel) / 2
11	Right Channel

9.7 Tone Configuration (Address 07h)

7	6	5	4	3	2	1	0
DeEmph	Loudness	EnDigHPF	TrebFc1	TrebFc0	BassFc1	BassFc0	EnToneCtrl

9.7.1 De-Emphasis Control (DeEmph)

Default = 0

Function:

Controls the operation of the internal de-emphasis filter. See [“De-Emphasis” on page 31](#) for more information.

DeEmph Setting	De-Emphasis State
0	No de-emphasis applied.
1	44.1 kHz 50/15 μ s de-emphasis filter applied.

9.7.2 Adaptive Loudness Compensation Control (Loudness)

Default = 0

Function:

Controls the operation of the adaptive loudness compensation feature. See [“Adaptive Loudness Compensation” on page 34](#) for more information.

Loudness Setting	Adaptive Loudness Compensation State
0	Disabled.
1	Enabled.

9.7.3 Digital Signal Processing High-Pass Filter (EnDigHPF)

Default = 0

Function:

Controls the operation of the digital signal processing high-pass filter. See [“Digital Signal Processing High-Pass Filter” on page 30](#) for more information.

EnDigHPF Setting	Digital Signal Processing High-Pass Filter State
0	Digital signal processing high-pass filter disabled.
1	Digital signal processing high-pass filter enabled.

9.7.4 Treble Corner Frequency (TrebFc[1:0])

Default = 00

Function:

Sets the corner frequency for the treble shelving filter as shown below.

TrebFc[1:0] Setting	Treble Corner Frequency
00	Selects Treble Fc 0 - Approximately 5 kHz
01	Selects Treble Fc 1 - Approximately 7 kHz
10	Selects Treble Fc 2 - Approximately 10 kHz
11	Selects Treble Fc 3 - Approximately 15 kHz

9.7.5 Bass Corner Frequency (BassFc[1:0])

Default = 01

Function:

Sets the corner frequency for the bass shelving filter as shown below.

BassFc[1:0] Setting	Bass Corner Frequency
00	Selects Bass Fc 0 - Approximately 50 Hz
01	Selects Bass Fc 1 - Approximately 100 Hz
10	Selects Bass Fc 2 - Approximately 200 Hz
11	Selects Bass Fc 3 - Approximately 250 Hz

9.7.6 Tone Control Enable (EnToneCtrl)

Default = 0

Function:

When set, enables the bass and treble shelving filters. When cleared, disables the bass and treble shelving filters.

EnToneCtrl Setting	Tone Control Filter State
0	Bass and treble shelving filters disabled.
1	Bass and treble shelving filters enabled.

9.8 Tone Control (Address 08h)

7	6	5	4	3	2	1	0
Treble3	Treble2	Treble1	Treble0	Bass3	Bass2	Bass1	Bass0

9.8.1 Treble Gain Level (Treb[3:0])

Default = 1000

Function:

Sets the gain/attenuation level of the treble shelving filter. The level can be adjusted in 1.5 dB increments from +12.0 to -10.5 dB.

Treb[3:0] Setting	Treble Shelving Filter Gain/Attenuation
0000	+12 dB
0001	+10.5 dB
.....
1000	0 dB
.....
1110	-9.0 dB
1111	-10.5 dB

9.8.2 Bass Gain Level (Bass[3:0])

Default = 1000

Function:

Sets the gain/attenuation level of the bass shelving filter. The level can be adjusted in 1.5 dB increments from +12.0 to -10.5 dB.

Bass[3:0] Setting	Bass Shelving Filter Gain/Attenuation
0000	+12 dB
0001	+10.5 dB
.....	
1000	0 dB
.....	
1110	-9.0 dB
1111	-10.5 dB

9.9 2.1 Bass Manager/Parametric EQ Control (Address 09h)

7	6	5	4	3	2	1	0
Freeze	Reserved	BassMgr2	BassMgr1	BassMgr0	EnLFEPEq	EnChBPEq	EnChAPEq

9.9.1 Freeze Controls (Freeze)

Default = 0

Function:

This function will freeze the previous output of, and allow modifications to be made to the master volume control (address 57h), channel X volume control (address 58h - 5Ah), and bi-quad coefficients for channel 1, channel 2 and channel 3 (address 0Ah - 54h) registers without the changes taking effect until the Freeze bit is disabled. To make multiple changes in these control port registers take effect simultaneously, enable the Freeze bit, make all register changes, then disable the Freeze bit.

Freeze Setting	Register Freeze State
0	Register freeze disabled.
1	Register freeze enabled.

9.9.2 Bass Cross-Over Frequency (BassMgr[2:0])

Default = 000

Function:

Controls the operation and cross-over frequency of the bass manager. See [“Bass Management” on page 35](#) for more information.

BassMgr[2:0] Setting	Bass Manager Crossover Setting
000	Bass manager disabled.
001	Selects Bass Manager Frequency 1 - Approximately 80 Hz
010	Selects Bass Manager Frequency 2 - Approximately 120 Hz
011	Selects Bass Manager Frequency 3 - Approximately 160 Hz
100	Selects Bass Manager Frequency 4 - Approximately 200 Hz
101	Selects Bass Manager Frequency 5 - Approximately 240 Hz
110	Selects Bass Manager Frequency 6 - Approximately 280 Hz
111	Selects Bass Manager Frequency 7 - Approximately 320 Hz

9.9.3 Enable LFE Parametric EQ (EnLFEPEq)

Default = 0

Function:

Enables the parametric EQ 4 and 5 bi-quad filters for the LFE channel.

EnLFEPEq Setting	LFE Parametric EQ State
0	Disabled.
1	Enabled.

9.9.4 Enable Channel B Parametric EQ (EnChBPEq)

Default = 0

Function:

Enables the parametric EQ 1, 2, and 3 bi-quad filters for channel B.

EnChBPEq Setting	Channel B Parametric EQ State
0	Disabled.
1	Enabled.

9.9.5 Enable Channel A Parametric EQ (EnChAPEq)

Default = 0

Function:

Enables the parametric EQ 1, 2, and 3 bi-quad filters for channel A.

EnChAPEq Setting	Channel A Parametric EQ State
0	Disabled.
1	Enabled.

9.10 Volume and 2-Way Cross-Over Configuration (Address 55h)

7	6	5	4	3	2	1	0
SZCMode1	SZCMode0	Mute50/50	AutoMute	En2Way	2WayFreq2	2WayFreq1	2WayFreq0

9.10.1 Soft Ramp and Zero Cross Control (SZCMode[1:0])

Default = 10

Function:

Sets the soft ramp and zero crossing detection modes by which volume and muting changes will be implemented.

SZCMode[1:0] Setting	Soft Ramp & Zero Crossing Mode
00	Immediate Change When immediate change is selected, all level changes will take effect immediately in one step.
01	Zero Cross Zero cross dictates that signal level changes, both muting and attenuation, will occur on a signal zero crossing to minimize audible artifacts. The requested level change will occur after a timeout period (approximately 18.7 ms for a PWM switch rate of 384/768 kHz and 17.0 ms for a PWM switch rate of 421.875/843.75 kHz) if the signal does not encounter a zero crossing. The zero cross function is independently monitored and implemented for each channel.
10	Soft Ramp Soft ramp allows level changes, both muting and attenuation, to be implemented by incrementally ramping, in ½ dB steps, from the current level to the new level at a rate of ½ dB per 4 sample periods for 32, 44.1, and 48 kHz, and ½ dB per 8 sample periods for 96 kHz.
11	Soft Ramp on Zero Cross Soft ramp on zero cross dictates that signal level changes, both muting and attenuation, will occur in ½ dB steps and be implemented on a signal zero crossing. The ½ dB level change will occur after a timeout period (approximately 18.7 ms for a PWM switch rate of 384/768 kHz and 17.0 ms for a PWM switch rate of 421.875/843.75 kHz) if the signal does not encounter a zero crossing. The zero cross function is independently monitored and implemented for each channel.

9.10.2 Enable 50% Duty Cycle for Mute Condition (Mute50/50)

Default = 0

Function:

Enables the outputs of the amplifiers to switch at an exact 50%-duty-cycle signal (not modulated) for all mute conditions. This bit does not cause a mute condition to occur. The Mute50/50 bit only defines operation during a normal mute condition.

Mute50/50 Setting	50% Duty Cycle Mute State
0	50% duty cycle for mute conditions disabled.
1	50% duty cycle for mute conditions enabled.

9.10.3 Auto-Mute (AutoMute)

Default = 1

Function:

When enabled, the outputs of the CS4525 will mute following the reception of 8192 consecutive audio samples of static 0 or -1. A single sample of non-static data will release the mute. Detection and muting is done independently for each channel. See [“Volume and Muting Control” on page 36](#) for more information.

AutoMute Setting	AutoMute State
0	Auto-mute on static 0's or -1's disabled.
1	Auto-mute on static 0's or -1's enabled.

9.10.4 Enable 2-Way Crossover (En2Way)

Default = 0

Function:

Enables the 2-way crossover filters for channel 1 and channel 2.

En2Way Setting	2-Way Crossover State
0	2-way crossover disabled.
1	2-way crossover enabled.

9.10.5 2-Way Cross-Over Frequency (2WayFreq[2:0])

Default = 000

Function:

Selects the cross-over frequency for the 2-Way Linkwitz-Riley filters.

2WayFreq Setting	2-Way Crossover Frequency
000	Selects X-Over Freq 0 - Approximately 2.0 kHz
001	Selects X-Over Freq 1 - Approximately 2.2 kHz
010	Selects X-Over Freq 2 - Approximately 2.4 kHz
011	Selects X-Over Freq 3 - Approximately 2.6 kHz
100	Selects X-Over Freq 4 - Approximately 2.8 kHz
101	Selects X-Over Freq 5 - Approximately 3.0 kHz
110	Selects X-Over Freq 6 - Approximately 3.2 kHz
111	Selects X-Over Freq 7 - Approximately 3.4 kHz

9.11 Channel 1-2: 2-Way Sensitivity Control (Address 56h)

7	6	5	4	3	2	1	0
LowPass3	LowPass2	LowPass1	LowPass0	HighPass3	HighPass2	HighPass1	HighPass0

9.11.1 Channel 1 and Channel 2 Low-Pass Sensitivity Adjust (LowPass[3:0])

Default = 0000

Function:

Controls the 2-way cross-over low-pass sensitivity adjustment. See [“2-Way Crossover & Sensitivity Control” on page 41](#) for more information.

LowPass[3:0] Setting	Sensitivity Compensation Level
0000	0.0 dB
0001	-0.5 dB
0010	-1.0 dB
.....	
1000	-4.0 dB
.....	
1110	-7.0 dB
1111	-7.5 dB

9.11.2 Channel 1 and Channel 2 High-Pass Sensitivity Adjust (HighPass[3:0])

Default = 0000

Function:

Controls the 2-way cross-over high-pass sensitivity adjustment. See [“2-Way Crossover & Sensitivity Control” on page 41](#) for more information.

HighPass[3:0] Setting	Sensitivity Compensation Level
0000	0.0 dB
0001	-0.5 dB
0010	-1.0 dB
.....	
1000	-4.0 dB
.....	
1110	-7.0 dB
1111	-7.5 dB

9.12 Master Volume Control (Address 57h)

7	6	5	4	3	2	1	0
MVol7	MVol6	MVol5	MVol4	MVol3	MVol2	MVol1	MVol0

9.12.1 Master Volume Control (MVol[7:0])

Default = 30h

Function:

Sets the gain/attenuation level of the master volume control. See [“Volume and Muting Control” on page 36](#) for more information.

MVol[7:0] Setting	Master Volume Setting
0000 0000	+24 dB
.....	
0011 0000	0.0 dB
0011 0001	-0.5 dB
0011 0010	-1.0 dB
.....	
1111 1110	-103.0 dB
1111 1111	Master Mute

9.13 Channel 1, 2, & 3 Volume Control (Address 58h, 59h, & 5Ah)

7	6	5	4	3	2	1	0
ChXVol7	ChXVol6	ChXVol5	ChXVol4	ChXVol3	ChXVol2	ChXVol1	ChXVol0

9.13.1 Channel X Volume Control (ChXVol[7:0])

Default = 30h

Function:

Sets the gain/attenuation levels of the channel 1, 2, and 3 individual volume controls. See “Volume and Muting Control” on page 36 for more information.

ChXVol[7:0] Setting	Channel X Volume Setting
0000 0000	+24 dB
0011 0000	0.0 dB
0011 0001	-0.5 dB
0011 0010	-1.0 dB
1111 1110	-103.0 dB
1111 1111	Channel Mute

9.14 Mute/Invert Control (Address 5Bh)

7	6	5	4	3	2	1	0
InvADC	InvCh3	InvCh2	InvCh1	MuteADC	MuteCh3	MuteCh2	MuteCh1

9.14.1 ADC Invert Signal Polarity (InvADC)

Default = 0

Function:

When set, the signal polarity of the ADC will be inverted.

InvADC Setting	ADC Signal Inversion State
0	ADC signal polarity not inverted.
1	ADC signal polarity inverted.

9.14.2 Invert Signal Polarity (InvChX)

Default = 0

Function:

When set, the signal polarity of the respective channels will be inverted.

InvChX Setting	Channel X Signal Inversion State
0	Channel X signal polarity not inverted.
1	Channel X signal polarity inverted.

9.14.3 ADC Channel Mute (MuteADC)

Default = 0

Function:

The output of the ADC will mute when enabled.

MuteADC Setting	ADC Mute State
0	ADC un-muted.
1	ADC muted.

9.14.4 Independent Channel Mute (MuteChX)

Default = 0

Function:

The PWM outputs of the CS4525 will mute when enabled. The muting function is affected, similar to attenuation changes, by the soft and zero cross bits (SZCMode[1:0]). See [“Volume and Muting Control” on page 36](#) for more information.

MuteChX Setting	Channel X Mute State
0	Channel X un-muted.
1	Channel X muted.

9.15 Limiter Configuration 1 (Address 5Ch)

7	6	5	4	3	2	1	0
Max2	Max1	Max0	Min2	Min1	Min0	LimitAll	EnLimiter

9.15.1 Maximum Threshold (Max[2:0])

Default = 000

Function:

Sets the maximum level, below full scale, at which to limit and attenuate the output signal at the limiter attack rate.

Max[2:0] Setting	Maximum Threshold Setting
000	0.0 dB
001	-3.0 dB
010	-6.0 dB
011	-9.0 dB
100	-12.0 dB
101	-18.0 dB
110	-24.0 dB
111	-30.0 dB

9.15.2 Minimum Threshold (Min[2:0])

Default = 000

Function:

Sets a minimum level below full scale at which the limiter will begin to release its applied attenuation.

Min[2:0] Setting	Minimum Threshold Setting
000	0.0 dB
001	-3.0 dB
010	-6.0 dB
011	-9.0 dB
100	-12.0 dB
101	-18.0 dB
110	-24.0 dB
111	-30.0 dB

9.15.3 Peak Signal Limit All Channels (LimitAll)

Default = 1

Function:

When cleared, the peak signal limiter will limit the maximum signal amplitude to prevent clipping on the specific channel indicating clipping. The other channels will not be affected. When set, the peak signal

limiter will limit the maximum signal amplitude to prevent clipping on all channels in response to any single channel indicating clipping. See [“Peak Signal Limiter” on page 37](#) for more information.

LimitAll Setting	Limit All Channels Configuration
0	Only individual channels affected by any limiter event.
1	All channels affected by any limiter event.

9.15.4 Peak Detect and Limiter Enable (EnLimiter)

Default = 0

Function:

Limits the maximum signal amplitude to prevent clipping when this function is enabled. Peak signal limiting is performed by digital attenuation.

EnLimiter Setting	Peak Signal Limiter State
0	Peak signal limiter disabled.
1	Peak signal limiter enabled.

9.16 Limiter Configuration 2 (Address 5Dh)

7	6	5	4	3	2	1	0
Reserved	Reserved	RRate5	RRate4	RRate3	RRate2	RRate1	RRate0

9.16.1 Limiter Release Rate (RRate[5:0])

Default = 000000

Function:

Sets the rate at which the limiter releases the digital attenuation from levels below the minimum setting in the limiter threshold register.

The limiter release rate is a function of the sampling frequency, F_s , and the soft and zero cross setting.

RRate[5:0] Setting	Limiter Release Rate
00000	Fastest release.
.....
11111.....	Slowest release.

9.17 Limiter Configuration 3 (Address 5Eh)

7	6	5	4	3	2	1	0
Reserved	Reserved	ARate5	ARate4	ARate3	ARate2	ARate1	ARate0

9.17.1 Limiter Attack Rate (ARate[5:0])

Default = 000000

Function:

Sets the rate at which the limiter attenuates the analog output from levels above the maximum setting in the limiter threshold register. The limiter attack rate is a function of the sampling frequency, F_s , and the soft and zero cross setting.

ARate[5:0] Setting	Limiter Attack Rate
00000	Fastest attack.
.....
11111.....	Slowest attack.

9.18 Power Control (Address 5Fh)

7	6	5	4	3	2	1	0
Reserved	Reserved	SelectVD	PDnADC	PDnOut3/4	PDnOut2	PDnOut1	PDnAll

9.18.1 Select VD Level (SelectVD)

Default = 1

Function:

This bit selects between a VD of 2.5 V or 3.3 V when the LVD pin is connected to DGND. This bit is ignored when the LVD pin is connected to VD.

SelectVD Setting	Selected VD Level
0	VD = 2.5 V.
1	VD = 3.3 V.

9.18.2 Power Down ADC (PDnADC)

Default = 1

Function:

The ADC will enter a power down state when this bit is enabled.

PDnADC Setting	ADC Power-Down State
0	Normal ADC operation.
1	ADC power-down enabled.

9.18.3 Power Down PWM Power Output X (PDnOutX)

Default = 1

Function:

When set, the specific PWM power output will enter a power-down state. Only the output power stage is powered down. The PWM modulator is not affected, nor is the setup or delay register values. When set to normal operation, the specific output will power up according to the state of the RmpSpd[1:0] bits and the channel output configuration selected. When transitioning from normal operation to power down, the specific output will power down according to the state of the RmpSpd[1:0] bits and the channel output configuration selected.

PDnChX Setting	Power Output X Power-Down State
0	Normal power output X operation.
1	Power output X power-down enabled.

9.18.4 Power Down (PDnAll)

Default = 1

Function:

The entire device will enter a low-power state when this function is enabled, and the contents of the control registers are retained in this mode. The power-down bit defaults to 'enabled' on power-up and must be disabled before normal operation can occur.

PDnAll Setting	Device Power-Down State
0	Normal device operation.
1	Device power-down enabled.

9.19 Interrupt Register (Address 60h)

7	6	5	4	3	2	1	0
SRCLock	ADCOvfl	ChOvfl	AmpErr	SRCStateM	ADCOvflM	ChOvflM	AmpErrM

Bits [7:4] in this register are read only. A '1'b in these bit positions indicates that the associated condition has occurred at least once since the register was last read. A '0'b indicates that the associated condition has not occurred since the last reading of the register. Reading the register resets bits to [7:4] '0'b. These bits are considered "edge-trigger" events. The operation of these 4 bits is not affected by the interrupt mask bits and the condition of each bit can be polled instead of generating an interrupt as required.

9.19.1 SRC Lock State Transition Interrupt Bit (SRCLock)

Default = 0

Function:

This bit is read only. When set, indicates that the SRC has transitioned from an unlock to lock state or from a lock state to an unlock state since the last read of this register. Conditions which cause the SRC to transition states, such as loss of LRCK, SCLK, an LRCK ratio change, or the SRC achieving lock, will cause this bit to be set. This interrupt bit is an edge-triggered event and will be cleared following a read of this register.

If this bit is set, indicating a SRC state change condition, and the SRCLockM bit is set, the INT pin will go active. To determine the current lock state of the SRC, read the SRCLockSt bit in the interrupt status register.

SRCLock Setting	SRC Lock State Change Status
0	SRC lock state unchanged since last read of this register.
1	SRC lock state changed since last read of this register.

9.19.2 ADC Overflow Interrupt Bit (ADCOvfl)

Default = 0

Function:

This bit is read only. When set, indicates that an over-range condition occurred anywhere in the CS4525 ADC signal path and has been clipped to positive or negative full scale as appropriate since the last read of this register. This interrupt bit is an edge-triggered event and will be cleared following a read of this register.

If this bit is set, indicating an ADC over-range condition, and the ADCOvflM bit is set, the INT pin will go active. To determine the current overflow state of the ADC, read the ADCOvflSt bit in the interrupt status register.

ADCOvfl Setting	ADC Overflow Event Status
0	ADC overflow condition has not occurred since last read of this register.
1	ADC overflow condition has occurred since last read of this register.

9.19.3 Channel Overflow Interrupt Bit (ChOvfl)

Default = 0

Function:

This bit is read only. When set, indicates that the magnitude of an output sample on channel 1, 2, or 3 has exceeded full scale and has been clipped to positive or negative full scale as appropriate since the last read of this register. This interrupt bit is an edge-triggered event and will be cleared following a read of this register.

If this bit is set, indicating a channel over-range condition, and the ChOvfIM bit is set, the INT pin will go active. To determine the current overflow state of each channel, read the ChXOvfISt bits in the interrupt status register.

ChOvfI Setting	Channel Overflow Event Status
0	A channel overflow condition has not occurred since last read of this register.
1	A channel overflow condition has occurred since last read of this register.

9.19.4 Amplifier Error Interrupt Bit (AmpErr)

Default = 0

Function:

This bit is read only. When set, indicates that an error was detected in the power amplifier section since the last read of this register. This interrupt bit is an edge-triggered event and will be cleared following a read of this register. This bit is the logical OR of all the bits in the amplifier error status register. Read the amplifier error status register to determine which condition occurred.

If this bit is set, indicating an amplifier stage error condition, and the AmpErrM bit is set to a '1'b, the INT pin will go active. To determine the actual current state of the amplifier error condition, read the amplifier error status register.

AmpErr Setting	Amplifier Error Event Status
0	An amplifier error condition has not occurred since last read of this register.
1	An amplifier error condition has occurred since last read of this register.

9.19.5 Mask Bit for SRC State (SRCLockM)

Default = 0

Function:

This bit serves as a mask for the SRC status interrupt source. If this bit is set, the SRCLock interrupt is unmasked, meaning that if the SRCLock bit is set, the INT pin will go active. If the SRCLockM bit is cleared, the SRCLock condition is masked, meaning that its occurrence will not affect the INT pin. However, the SRCLock and SRCLockSt bits will continue to reflect the lock status of the SRC.

SRCLockM Setting	SRCLock INT Pin Mask State
0	SRCLock condition masked.
1	SRCLock condition un-masked.

9.19.6 Mask Bit for ADC Overflow (ADCOvfIM)

Default = 0

Function:

This bit serves as a mask for the ADC overflow interrupt source. If this bit is set, the ADCOvfI interrupt is unmasked, meaning that if the ADCOvfI bit is set, the INT pin will go active. If the ADCOvfIM bit is cleared, the ADCOvfI condition is masked, meaning that its occurrence will not affect the INT pin. However, the ADCOvfI and ADCOvfISt bits will continue to reflect the overflow state of the ADC.

ADCOvfIM Setting	ADCOvfI INT Pin Mask State
0	ADCOvfI condition masked.
1	ADCOvfI condition un-masked.

9.19.7 Mask Bit for Channel X Overflow (ChOvfIM)

Default = 0

Function:

This bit serves as a mask for the channel overflow interrupt source. If this bit is set, the ChOvfl interrupt is unmasked, meaning that if the ChOvfl bit is set, the INT pin will go active. If the ChOvfIM bit is cleared, the ChOvfl condition is masked, meaning that its occurrence will not affect the INT pin. However, the ChOvfl and ChXOvflSt bits will continue to reflect the overflow state of the individual channels.

ChOvfIM Setting	ChOvfl INT Pin Mask State
0	ChOvfl condition masked.
1	ChOvfl condition un-masked.

9.19.8 Mask Bit for Amplifier Error (AmpErrM)

Default = 0

Function:

This bit serves as a mask for the amplifier error interrupt sources. If this bit is set, the AmpErr interrupt is unmasked, meaning that if the AmpErr bit is set, the INT pin will go active. If the AmpErrM bit is cleared, the AmpErr condition is masked, meaning that its occurrence will not affect the INT pin. However, the AmpErr and the amplifier error bits in the amplifier error status register will continue to reflect the status of the amplifier error conditions.

AmpErrM Setting	AmpErr INT Pin Mask State
0	AmpErr condition masked.
1	AmpErr condition un-masked.

9.20 Interrupt Status Register (Address 61h) - Read Only

7	6	5	4	3	2	1	0
SRCLockSt	ADCOvflSt	Ch3OvflSt	Ch2OvflSt	Ch1OvflSt	RampDone	Reserved	Reserved

All bits in this register are considered “level-trigger” events, meaning as long as a condition continues, the corresponding bit will remain set. These status bits are not affected by the interrupt mask bit and the condition of each bit can be polled. These bits will not be cleared following a read to this register, nor can they be written to cause an interrupt condition.

9.20.1 SRC State Transition (SRCLockSt)

Default = 0

Function:

This bit is read only and reflects the current lock state of the SRC. When set, indicates the SRC is currently locked. When cleared, indicates the SRC is currently unlocked.

SRCLockSt Setting	SRC Lock State
0	SRC is currently unlocked.
1	SRC is currently locked.

9.20.2 ADC Overflow (ADCOvfl)

Default = 0

Function:

This bit is read only and will identify the presence of an overflow condition within the ADC. When set, indicates that an over-range condition is currently occurring in the CS4525 ADC signal path and has been clipped to positive or negative full scale.

ADCOvfl Setting	ADC Overflow State
0	An ADC overflow condition is not currently present.
1	An ADC overflow condition is currently present.

9.20.3 Channel X Overflow (ChXOvfl)

Default = 0

Function:

These bits are read only and will identify the presence of an overflow condition anywhere in the associated channel's signal path. When set, indicates that an over-range condition is currently occurring in the channel's signal path and has been clipped to positive or negative full scale.

ChXOvfl Setting	Channel X Overflow State
0	An overflow condition is not currently present on channel X.
1	An overflow condition is currently present on channel X.

9.20.4 Ramp-Up Cycle Complete (RampDone)

Default = 0

Function:

When set, indicates that all active channels have completed the configured ramp-up interval.

RampDone Setting	Ramp Completion State
0	Ramp-up interval not completed on all channels.
1	Ramp-up interval completed on all channels.

9.21 Amplifier Error Status (Address 62h) - Read Only

7	6	5	4	3	2	1	0
OverCurr4	OverCurr3	OverCurr2	OverCurr1	ExtAmpErr	UnderV	ThermErr	ThermWarn

All bits in this register are considered "level-trigger" events, meaning as long as a condition continues, the corresponding bit will remain set. These status bits are not affected by the interrupt mask bit and the condition of each bit can be polled. These bits will not be cleared following a read to this register, nor can they be written to cause an interrupt condition.

9.21.1 Over-Current Detected On Channel X (OverCurrX)

Default = 0

Function:

When set, indicates an over current condition is currently present on the corresponding amplifier output.

OverCurrX Setting	Amplifier Over-Current Status
0	An over current condition is not currently present on amplifier output X.
1	An over current condition is currently present on amplifier output X.

9.21.2 External Amplifier State (*ExtAmpSt*)

Default = 0

Function:

When set, indicates a thermal warning condition is currently being reported by an external amplifier. For proper operation, the delay serial port must be configured to support an external thermal warning input signal. This status bit reflects the active state of the external thermal warning input signal.

ExtAmpSt Setting	External Amplifier Status
0	A thermal warning condition is not currently being reported by an external amplifier.
1	A thermal warning condition is currently being reported by an external amplifier.

9.21.3 Under Voltage Detected (*UnderV*)

Default = 0

Function:

When set, indicates an undervoltage condition is currently present on the VP voltage rail.

UnderV Setting	VP Under Voltage Status
0	An under-voltage condition is not currently present on the VP supply.
1	An under-voltage condition is currently present on the VP supply.

9.21.4 Thermal Error Detected (*ThermErr*)

Default = 0

Function:

When set, indicates a thermal error condition (specified by the thermal error trip point listed in the [PWM Power Output Characteristics](#) table on [page 20](#)) is currently present.

ThermErr Setting	Thermal Error Status
0	A thermal error condition is not currently present.
1	A thermal error condition is currently present.

9.21.5 Thermal Warning Detected (*ThermWarn*)

Default = 0

Function:

When set, indicates a thermal warning condition (specified by the thermal warning trip point listed in the [PWM Power Output Characteristics](#) table on [page 20](#)) is currently present.

ThermWarn Setting	Thermal Warning Status
0	A thermal warning condition is not currently present.
1	A thermal warning condition is currently present.

9.22 Chip I.D. and Revision Register (Address 63h) - Read Only

7	6	5	4	3	2	1	0
DeviceID4	DeviceID3	DeviceID2	DeviceID1	DeviceID0	RevID2	RevID1	RevID0

9.22.1 Device Identification (DeviceID[4:0])

Default = 11000

Function:

Identification code for the CS4525.

DeviceID[4:0] Setting	Device ID Notes
11000.....	Permanent device identification code.

9.22.2 Device Revision (RevID[2:0])

Default = 000

Function:

CS4525 revision level.

RevID[2:0] Setting	Device Revision ID
000	Revision A0.

10. PARAMETER DEFINITIONS

Dynamic Range (DYR)

The ratio of the rms value of the signal to the rms sum of all other spectral components over the specified bandwidth, typically 20 Hz to 20 kHz. Dynamic Range is a signal-to-noise ratio measurement over the specified band width made with a -60 dBFS signal. 60 dB is then added to the resulting measurement to refer the measurement to full-scale. This technique ensures that the distortion components are below the noise level and do not effect the measurement. This measurement technique has been accepted by the Audio Engineering Society, AES17-1991, and the Electronic Industries Association of Japan, EIAJ CP-307. Expressed in decibels.

Total Harmonic Distortion + Noise (THD+N)

The ratio of the rms value of the signal to the rms sum of all other spectral components over the specified band width (typically 10 Hz to 20 kHz), including distortion components. Expressed in decibels. Measured at -1 and -20 dBFS as suggested in AES17-1991 Annex A.

Frequency Response

FR is the deviation in signal level verses frequency. The 0 dB reference point is 1 kHz. The amplitude corner, A_c , lists the maximum deviation in amplitude above and below the 1 kHz reference point. The listed minimum and maximum frequencies are guaranteed to be within the A_c from minimum frequency to maximum frequency inclusive.

Interchannel Isolation

A measure of crosstalk between the left and right channels. Measured for each channel at the converter's output with no signal to the input under test and a full-scale signal applied to the other channel. Units in decibels.

Interchannel Gain Mismatch

The gain difference between left and right channels. Units in decibels.

Gain Drift

The change in gain value with temperature. Units in ppm/°C.

F_s

Sampling Frequency.

Resolution

The number of bits in a serial audio data word.

SRC

Sample Rate Converter. Converts data derived at one sample rate to a differing sample rate.

11. REFERENCES

1. Cirrus Logic, "AN18: Layout and Design Rules for Data Converters and Other Mixed Signal Devices," Version 6.0, February 1998.
2. Cirrus Logic, "AN22: Overview of Digital Audio Interface Data Structures, Version 2.0", February 1998.; A useful tutorial on digital audio specifications.
3. Philips Semiconductor, "The I²C-Bus Specification: Version 2," Dec. 1998.
<http://www.semiconductors.philips.com>

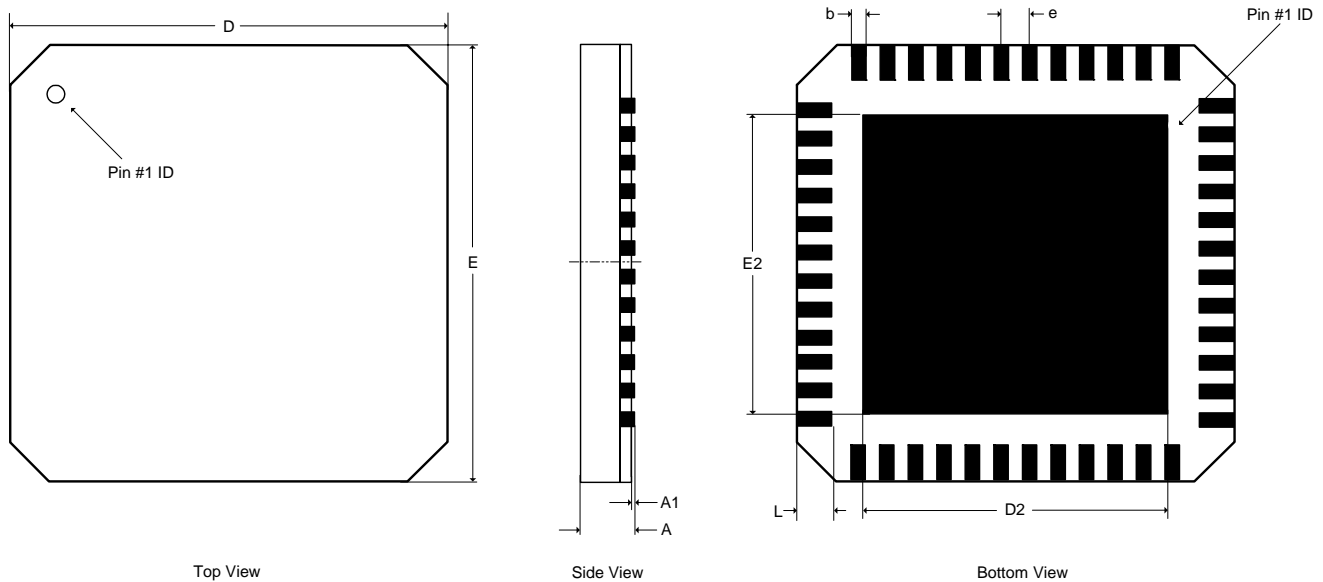
12.PACKAGE DIMENSIONS
48L QFN (9 × 9 MM BODY) PACKAGE DRAWING

DIM	INCHES			MILLIMETERS			NOTE
	MIN	NOM	MAX	MIN	NOM	MAX	
A	--	--	0.0354	--	--	0.90	1
A1	0.0000	--	0.0020	0.00	--	0.05	1
b	0.0118	0.0138	0.0157	0.30	0.35	0.40	1,2
D	0.3543 BSC			9.00 BSC			1
D2	0.2618	0.2677	0.2736	6.65	6.80	6.95	1
E	0.3543 BSC			9.00 BSC			1
E2	0.2618	0.2677	0.2736	6.65	6.80	6.95	1
e	0.0256 BSC			0.65 BSC			1
L	0.0177	0.0217	0.0276	0.45	0.55	0.70	1

JEDEC #: MO-220

Controlling Dimension is Millimeters.

Table 19:

- Notes:**
1. Dimensioning and tolerance per ASME Y4.5M - 1994.
 2. Dimensioning lead width applies to the plated terminal and is measured between 0.20 mm and 0.25 mm from the terminal tip.

13.THERMAL CHARACTERISTICS

Parameter	Symbol	Min	Typ	Max	Units
Junction to Case Thermal Impedance	θ_{JC}	-	1	-	°C/Watt

13.1 Thermal Flag

This device is designed to have the metal flag on the bottom of the device soldered directly to a metal plane on the PCB. To enhance the thermal dissipation capabilities of the system, this metal plane should be coupled with vias to a large metal plane on the backside (and inner ground layer, if applicable) of the PCB.

In either case, it is beneficial to use copper fill in any unused regions inside the PCB layout, especially those immediately surrounding the CS4525. In addition to improving in electrical performance, this practice also aids in heat dissipation.

The heat dissipation capability required of the metal plane for a given output power can be calculated as follows:

$$\theta_{CA} = [(T_{J(MAX)} - T_A) / P_D] - \theta_{JC}$$

where,

θ_{CA} = Thermal resistance of the metal plane in °C/Watt

$T_{J(MAX)}$ = Maximum rated operating junction temperature in °C, equal to 150 °C

T_A = Ambient temperature in °C

P_D = RMS power dissipation of the device, equal to $0.15 * P_{RMS}$ (assuming 85% efficiency)

θ_{JC} = Junction-to-case thermal resistance of the device in °C/Watt

14.ORDERING INFORMATION

Product	Description	Package	Pb-Free	Grade	Temp Range	Container	Order#
CS4525	Digital TV Amp with Integrated ADC	48-QFN	Yes	Commercial	-10° to +70°C	Rail	CS4525-CNZ
						Tape and Reel	CS4525-CNZR
CRD4525	2 x 15 W Reference Design Board	-	-	-	-	-	CRD4525
CRD4412	1 x 30 W Reference Design Daughter Card	-	-	-	-	-	CRD4412

15. REVISION HISTORY

Release	Changes
A1	Initial Release

Contacting Cirrus Logic Support

For all product questions and inquiries, contact a Cirrus Logic Sales Representative.

To find one nearest you, go to www.cirrus.com.

IMPORTANT NOTICE

“Advance” product information describes products that are in development and subject to development changes. Cirrus Logic, Inc. and its subsidiaries (“Cirrus”) believe that the information contained in this document is accurate and reliable. However, the information is subject to change without notice and is provided “AS IS” without warranty of any kind (express or implied). Customers are advised to obtain the latest version of relevant information to verify, before placing orders, that information being relied on is current and complete. All products are sold subject to the terms and conditions of sale supplied at the time of order acknowledgment, including those pertaining to warranty, indemnification, and limitation of liability. No responsibility is assumed by Cirrus for the use of this information, including use of this information as the basis for manufacture or sale of any items, or for infringement of patents or other rights of third parties. This document is the property of Cirrus and by furnishing this information, Cirrus grants no license, express or implied under any patents, mask work rights, copyrights, trademarks, trade secrets or other intellectual property rights. Cirrus owns the copyrights associated with the information contained herein and gives consent for copies to be made of the information only for use within your organization with respect to Cirrus integrated circuits or other products of Cirrus. This consent does not extend to other copying such as copying for general distribution, advertising or promotional purposes, or for creating any work for resale.

CERTAIN APPLICATIONS USING SEMICONDUCTOR PRODUCTS MAY INVOLVE POTENTIAL RISKS OF DEATH, PERSONAL INJURY, OR SEVERE PROPERTY OR ENVIRONMENTAL DAMAGE (“CRITICAL APPLICATIONS”). CIRRUS PRODUCTS ARE NOT DESIGNED, AUTHORIZED OR WARRANTED FOR USE IN AIRCRAFT SYSTEMS, MILITARY APPLICATIONS, PRODUCTS SURGICALLY IMPLANTED INTO THE BODY, AUTOMOTIVE SAFETY OR SECURITY DEVICES, LIFE SUPPORT PRODUCTS OR OTHER CRITICAL APPLICATIONS. INCLUSION OF CIRRUS PRODUCTS IN SUCH APPLICATIONS IS UNDERSTOOD TO BE FULLY AT THE CUSTOMER’S RISK AND CIRRUS DISCLAIMS AND MAKES NO WARRANTY, EXPRESS, STATUTORY OR IMPLIED, INCLUDING THE IMPLIED WARRANTIES OF MERCHANTABILITY AND FITNESS FOR PARTICULAR PURPOSE, WITH REGARD TO ANY CIRRUS PRODUCT THAT IS USED IN SUCH A MANNER. IF THE CUSTOMER OR CUSTOMER’S CUSTOMER USES OR PERMITS THE USE OF CIRRUS PRODUCTS IN CRITICAL APPLICATIONS, CUSTOMER AGREES, BY SUCH USE, TO FULLY INDEMNIFY CIRRUS, ITS OFFICERS, DIRECTORS, EMPLOYEES, DISTRIBUTORS AND OTHER AGENTS FROM ANY AND ALL LIABILITY, INCLUDING ATTORNEYS’ FEES AND COSTS, THAT MAY RESULT FROM OR ARISE IN CONNECTION WITH THESE USES.

Cirrus Logic, Cirrus, and the Cirrus Logic logo designs, and Popguard are trademarks of Cirrus Logic, Inc. All other brand and product names in this document may be trademarks or service marks of their respective owners.

IPC is a registered trademark of Philips Semiconductor.